

**Margaret Island Symposium 2022 on Vacuum Structure,
Particles and Plasmas**

**Theoretical
basis of
nano-
fusion**

**Laszlo P. Csernai, for the
NAPLIFE Collaboration
Univ. of Bergen, Norway
Budapest, May 15-18, 2022**



How to remedy the problems of present Laser Fusion trials of NIF@Livermore & OMEGA@Rochester

Two ideas are combined by L.P. Csernai, N. Kroo, I. Papp:
[Patent # P1700278/3] (2017)

Problems:

- Rayleigh-Taylor instability
- Slow propagation of burning from central hot-spot

Solution:

- Heat the system uniformly by radiation with **RFD (1)**
- Achieve uniform heating by **Nano-Technology (2)**

[L.P. Csernai, N. Kroo, I. Papp, *Laser and Particle Beams*, LPB, 36(2), (2018) 171-178. .

<https://doi.org/10.1017/S0263034618000149>]

But let us go back in history →



Kőszeg, September 14, 2019 - Int. Workshop on Collectivity
First meeting on the NAPLIFE project (12 people)

NAPLIFE Collaboration – Participants - ELKH, National Res. Lab.

Prof. Dr. Peter J. Lévai, Prof. Dr. Laszlo P. Csernai, Prof. Dr. Norbert Kroó, Prof. Dr. Tamás S. Biró, Dr. Márk Aladi, Dr. Roman Holomb, Dr. Miklós Kedves, Dr. Archana Kumari, Dr. István Papp, Dr. Péter Petrik, Dr. Péter Rácz, Dr. Béla Ráczkevi, Dr. István Rigó, Dr. Miklós Veres, Anett Szeledi, Ágnes Nagyné Szokol; Prof. Gábor Galbács, Dr. Balázs Bánhelyi, Dr. Mária Csete, Dr. Attila Czirják, Olivér Antal Fekete, Péter Földi, Emese Tóth, András Szenes, Dávid Vass; Prof. Dr. Attila Bonyár, Dr. Judit Kámán, Alexandra Borók; Zsolt Fogarassy, Kolos Molnár, Dr. Péter Dombi Dr. Melinda Szalóki, Laura Juhász; Prof. Dr. Horst Stoecker, Dr. Leonid Satarov, Dr. Anton Motornenko; Prof. Dr. Larissa Bravina, Dr. Evgeny E. Zabrodin; Prof. Dr. Igor N. Mishustin, Prof. Dr. Daniel D. Strottman, Dr. Csaba Tóth, Prof. Dr. Dénes Molnár, Shereen Zangana (~> 40)

Rayleigh-Taylor Instability

[Clark et al., Phys. Plasmas, **22**, 022703 (2015).]

Snapshots of 3D simulation
 22.53ns: peak impl. Velocity
 23.83ns: bang, max compr.
 22.96ns: jet out, up left
 Green surface: Ablator/DT-f.
 Peaks: Ablator defects
 Colours:
 Left: fluid speed
 Right: matter density

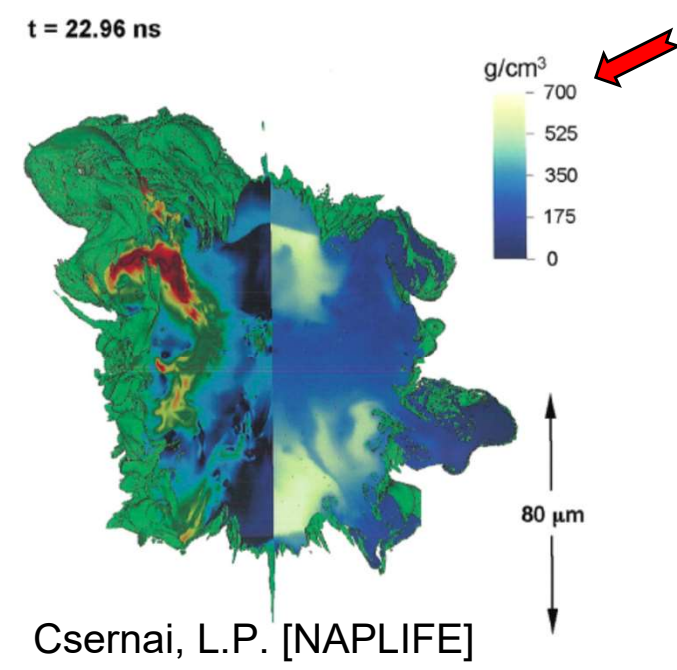
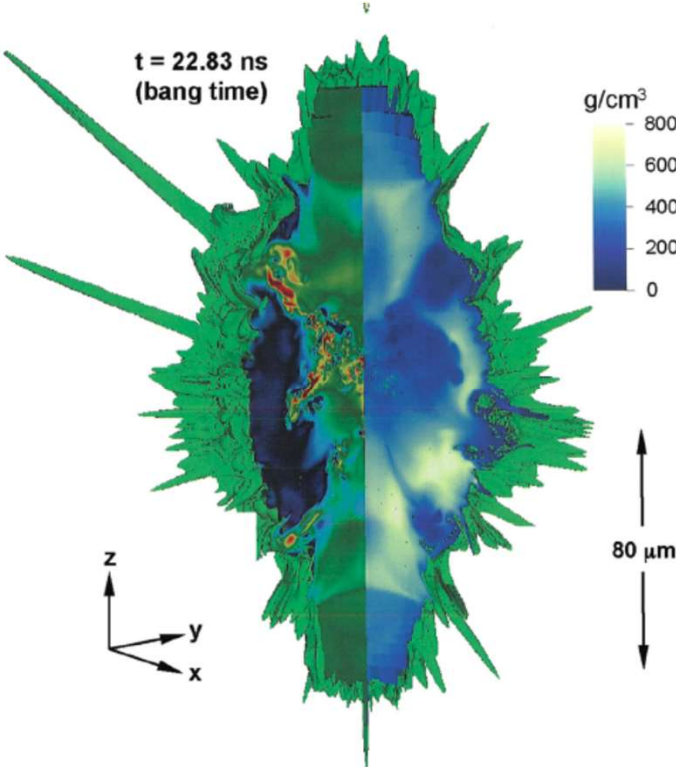
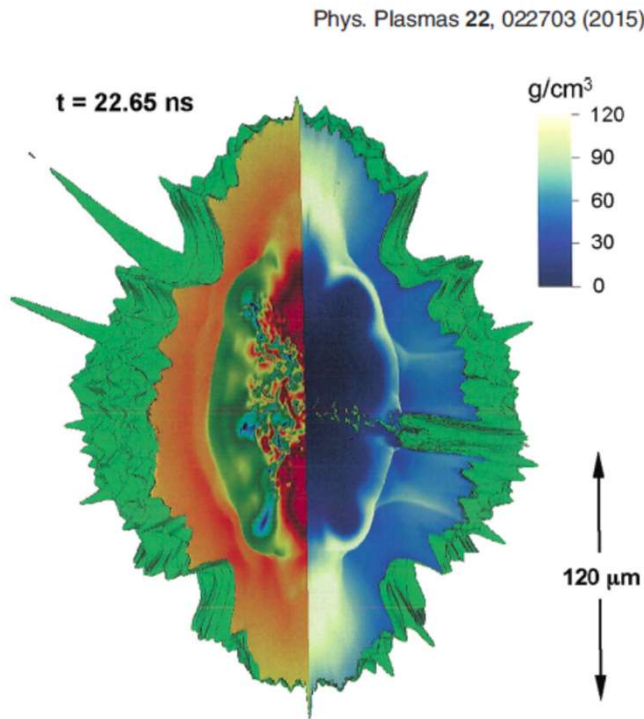
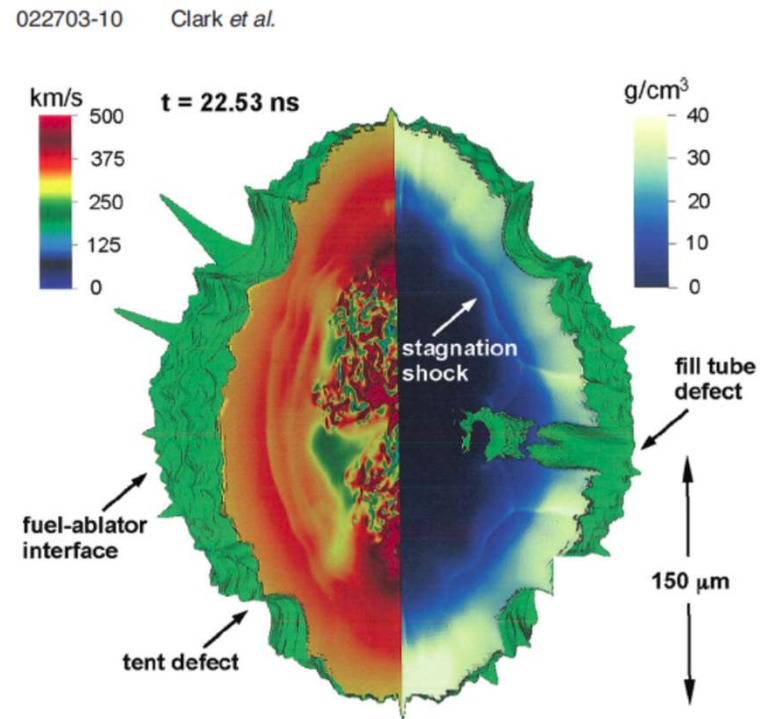

~adiabatic
 compression
 → 80 μm
 & heating

ITER torus

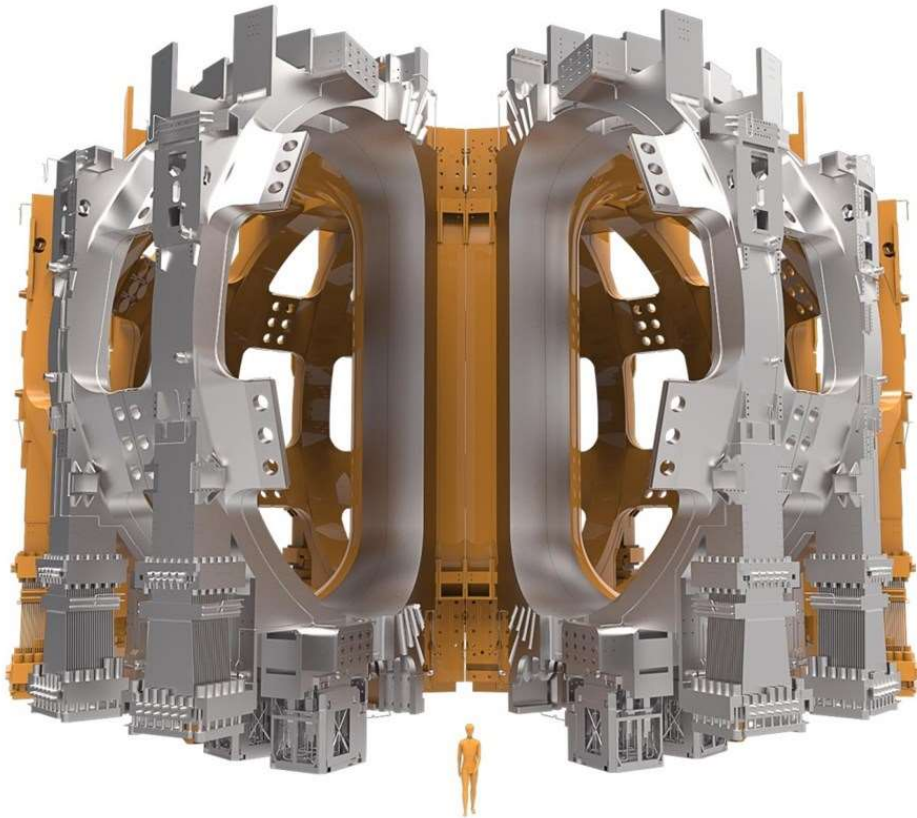

Under construction
Torus: 6x10x18m, $V=830 \text{ m}^3$,
 $Q=10$, planned
500MW\8min, plan
2008-2018 ??? >

RT instability

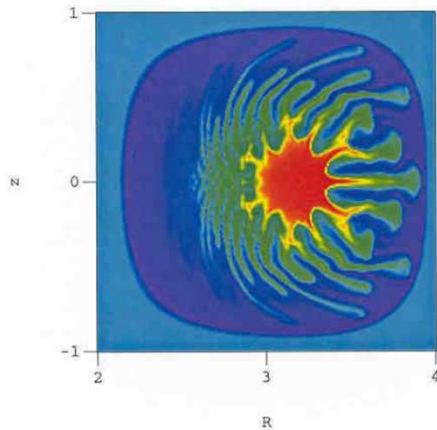
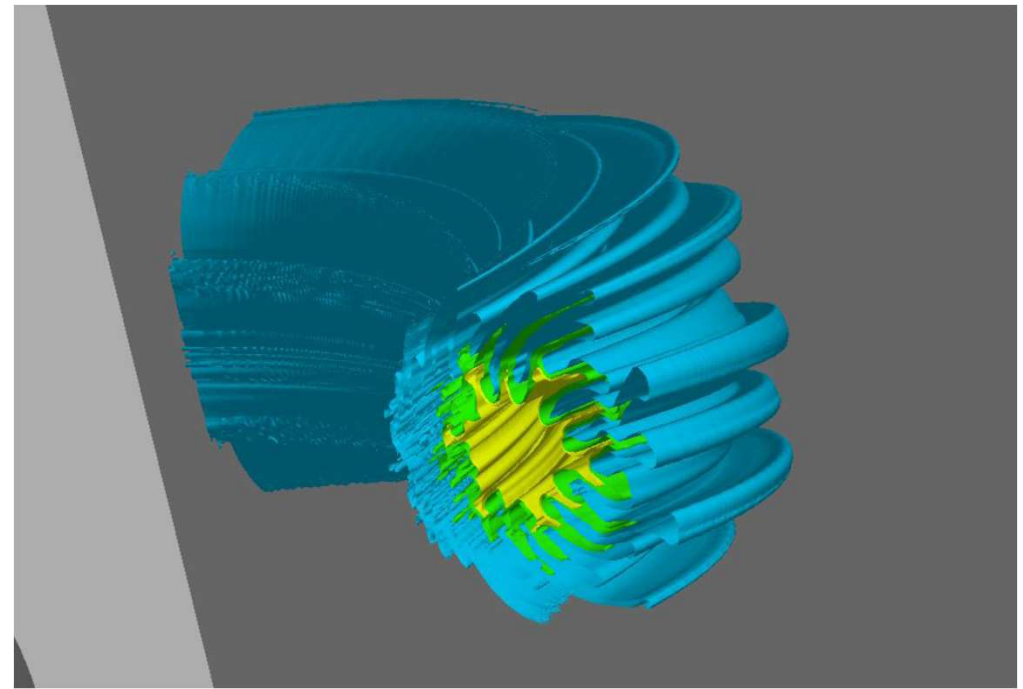

NIF – RT instability

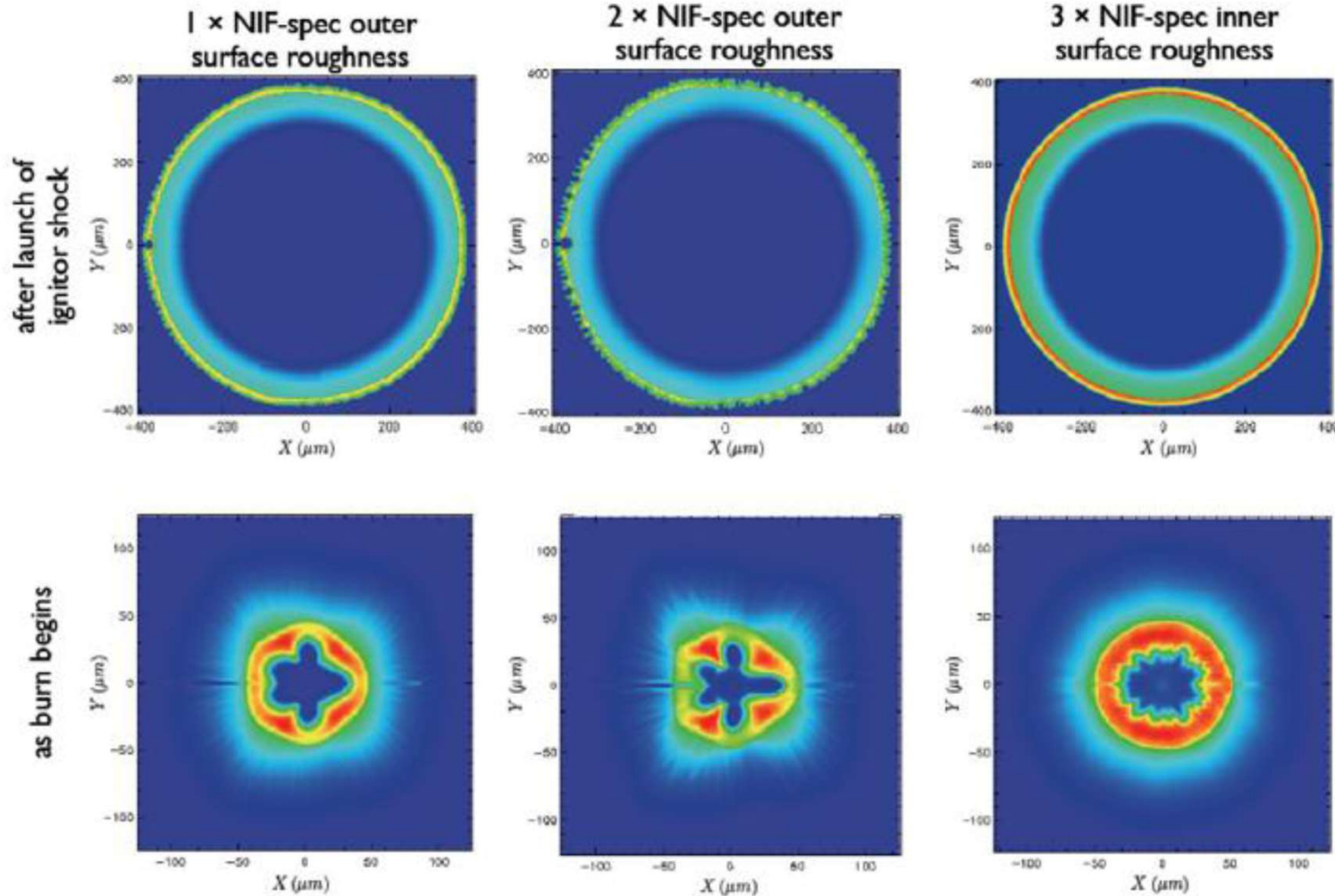

The target is compressed to density $\sim 700 \text{ g/cm}^3$.

But, although an ablator layer is used, only \sim **10%-of the target** is ignited.

Elsewhere the surface protruded as “potato from the potato press”:
RT- instability.

How can we prevent it

Idea - #1

[A.H. Taub (1948)]

PHYSICAL REVIEW

VOLUME 74, NUMBER 3

AUGUST 1, 1948

Relativistic Rankine-Hugoniot Equations

A. H. TAUB

*University of Illinois, Urbana, Illinois and Institute for Advanced Study, Princeton University, Princeton, New Jersey**

Next we suppose that the three-dimensional volume is a shell of thickness ϵ enclosing a surface of discontinuity Σ whose three-dimensional normal vector is Λ_i . If we choose our coordinate system so that the discontinuity is at rest, then since

$$\underline{\lambda_\alpha \lambda^\alpha = 1}, \quad \sum_{i=1}^3 \Lambda_i^2 = 1,$$

we have

$$\lambda_i = \Lambda_i \quad \text{and} \quad \underline{\lambda_4 = 0}.$$

Hence Eqs. (7.1) and (7.2) become, as ϵ goes to zero,

$$[\rho^0 u^i \Lambda_i] = 0, \quad (7.3)$$

$$[T^{\alpha i} \Lambda_i] = 0, \quad (7.4)$$

where

$$[f] = f_+ - f_-$$

Csernai, L.P. [NAPLIFE]

Taub assumed that (physically) only slow space-like shocks or discontinuities may occur (with space-like normal, $\lambda_4=0$).

This was then taken as standard, since then (e.g. LL 1954-)

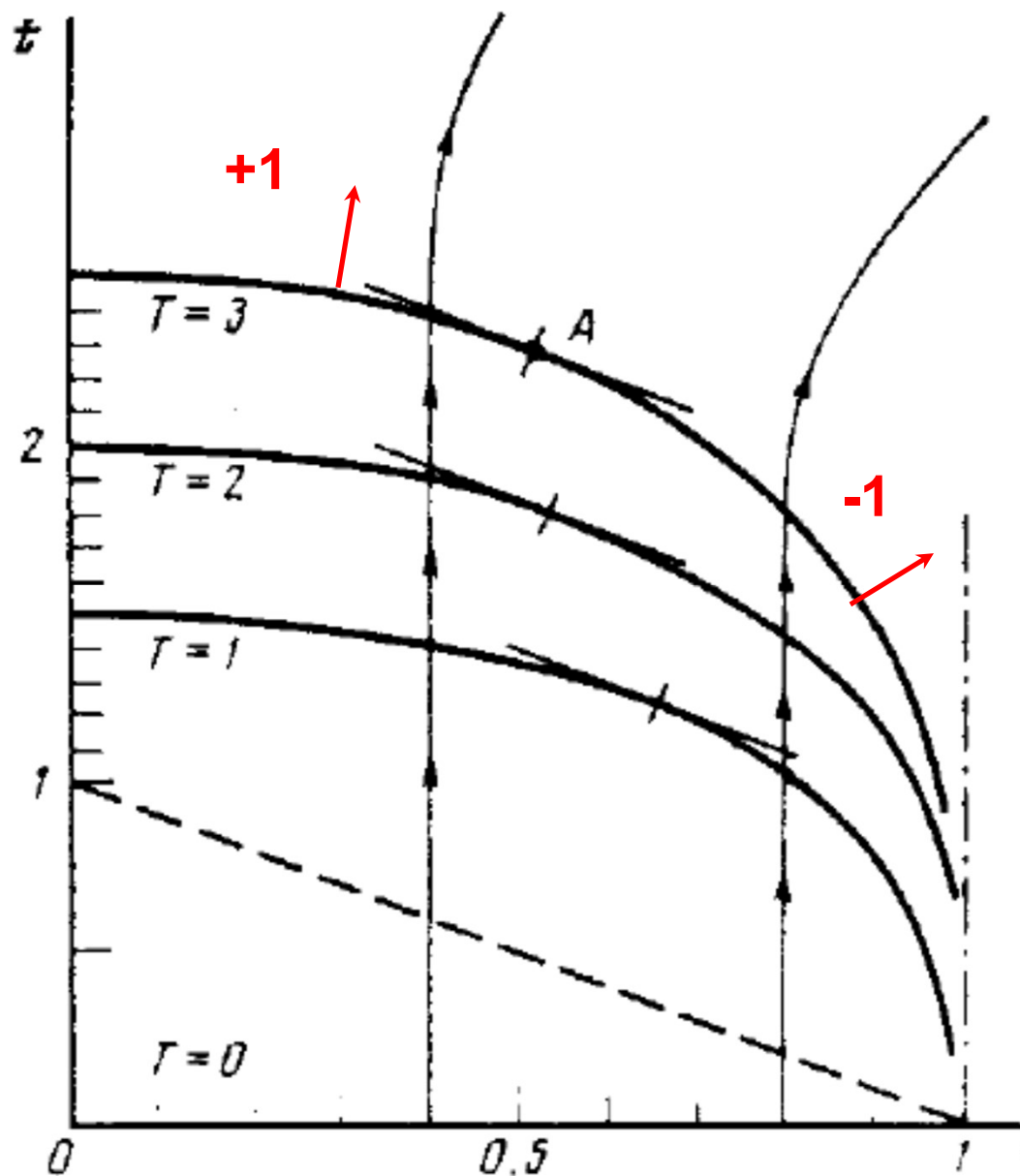

[L. P. Csernai, Zh. Eksp. Teor. Fiz. 92, 379-386 (**1987**) & Sov. Phys. JETP 65, 216-220 (1987)]

corrected the work of [**A. Taub**, Phys. Rev. 74, 328 (**1948**)]

$$\lambda_\alpha \lambda^\alpha = \pm 1$$

Л. П. Чернаи

**ДЕТОНАЦИЯ НА ВРЕМЕНИПОДОБНОМ ФРОНТЕ
ДЛЯ РЕЛЯТИВИСТСКИХ СИСТЕМ**

Журнал экспериментальной и теоретической физики

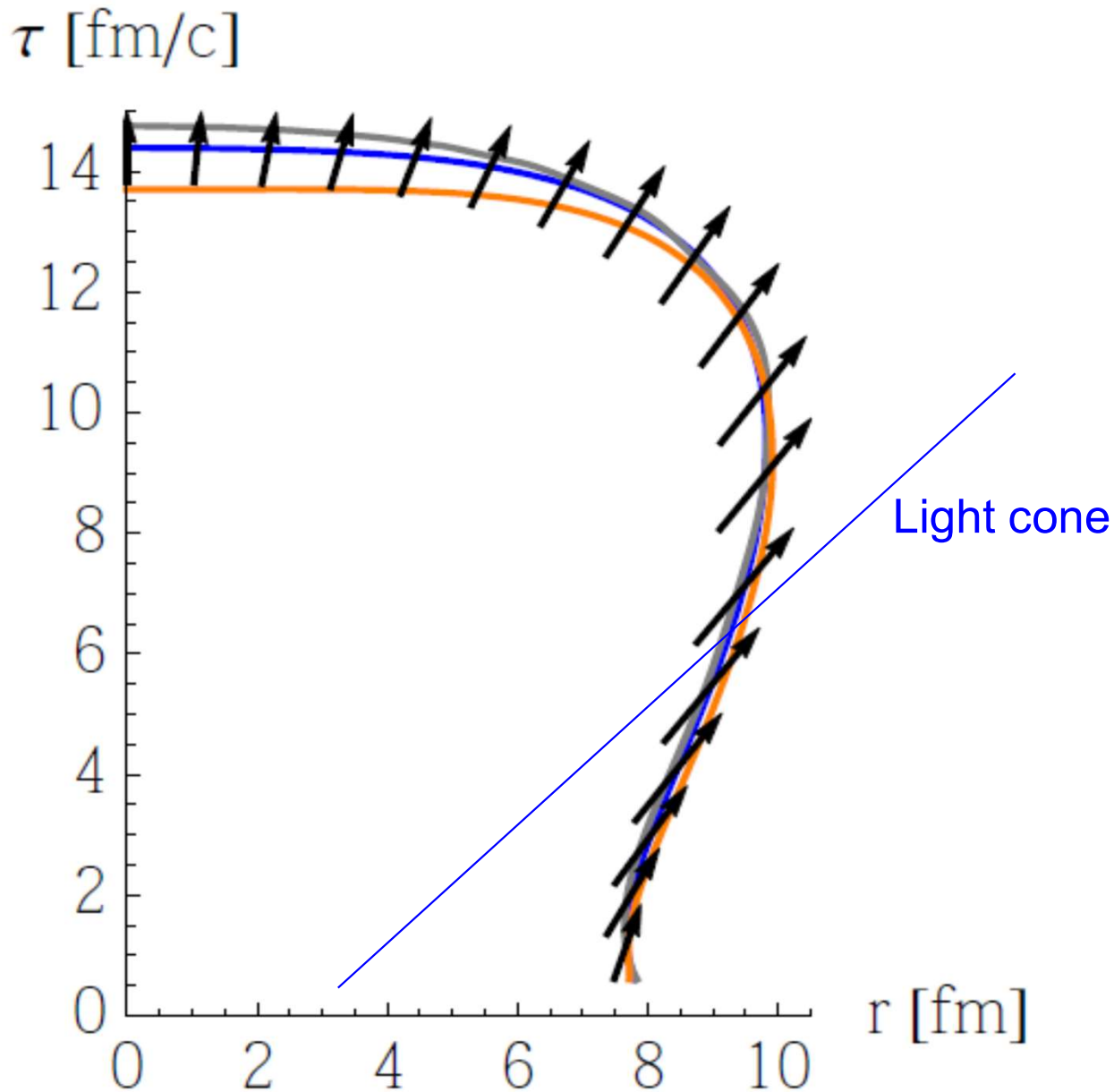

@ CERN in High energy heavy ion collisions

[Stefan Floerchinger, and Urs Achim Wiedemann, Phys. Rev. C 89, 034914 (2014)]

Fusion reaction:



Constant absorptivity,
Spherical irradiation

Ignition temperature = $T_1 \rightarrow$

Simultaneous, volume ignition up to
0.5 R (i.e. **12%** of the volume).

Not too good, but better than:

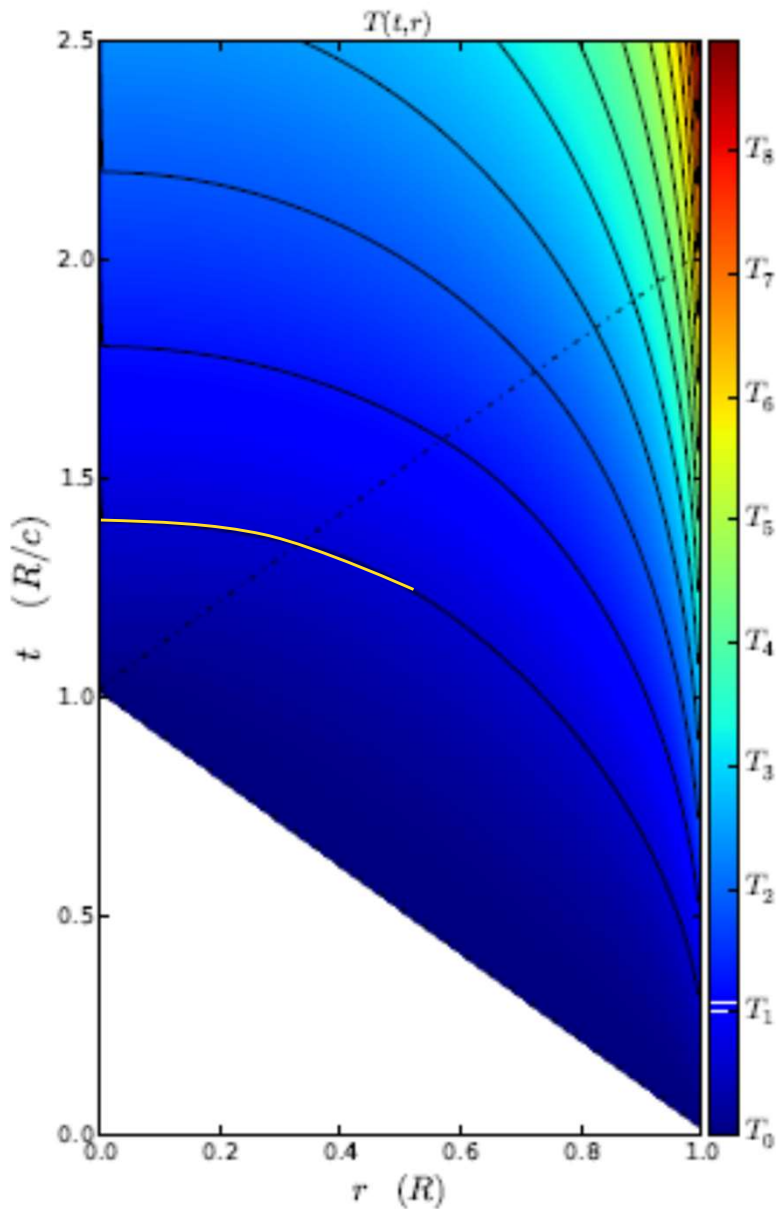
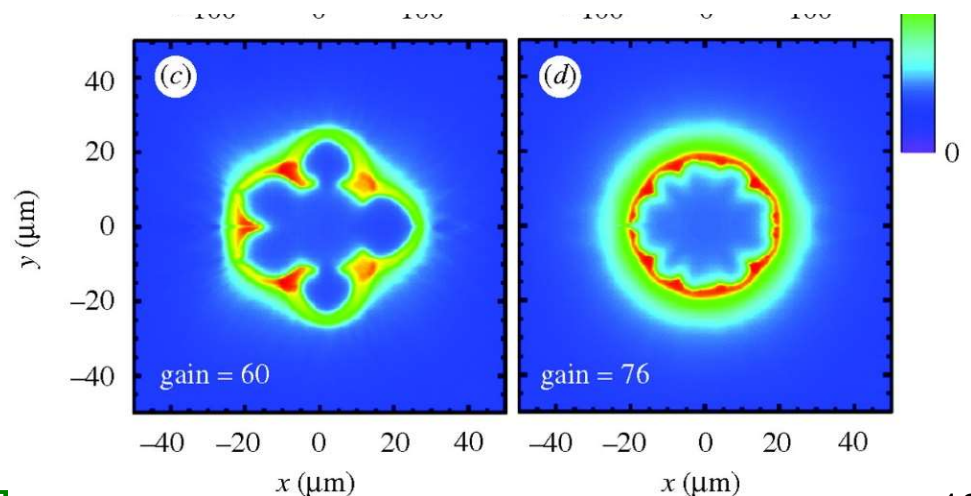

[L.P. Csernai & D.D. Strottman,
Laser and Particle Beams 33, 279 (2015).]

How can we realize it

Idea - #2

Research Article

Cite this article: Csernai LP, Kroo N, Papp I (2018). Radiation dominated implosion with nano-plasmonics. *Laser and Particle Beams* 1–8. <https://doi.org/10.1017/S0263034618000149>

Received: 28 November 2017

Revised: 14 March 2018

Accepted: 3 April 2018

Key words:

Inertial confinement fusion; nano-shells; relativistic fluid dynamics; time-like detonation

Author for correspondence:

L.P. Csernai, Department of Physics and Technology, University of Bergen, Bergen, Norway. E-mail: Laszlo.Csernai@uib.no

... and 35th Hirschegg
Int. Workshop on High
Energy Density
Physics, Jan. 25-30,
2015

Radiation dominated implosion with nano-plasmonics

L.P. Csernai¹, N. Kroo^{2,3} and I. Papp⁴

¹Department of Physics and Technology, University of Bergen, Bergen, Norway; ²Hungarian Academy of Sciences, Budapest, Hungary; ³Wigner Research Centre for Physics, Budapest, Hungary and ⁴Department of Physics, Babes-Bolyai University, Cluj, Romania

Abstract

Inertial Confinement Fusion is a promising option to provide massive, clean, and affordable energy for mankind in the future. The present status of research and development is hindered by hydrodynamical instabilities occurring at the intense compression of the target fuel by energetic laser beams. A recent patent combines advances in two fields: Detonations in relativistic fluid dynamics (RFD) and radiative energy deposition by plasmonic nano-shells. The initial compression of the target pellet can be decreased, not to reach the Rayleigh–Taylor or other instabilities, and rapid volume ignition can be achieved by a final and more energetic laser pulse, which can be as short as the penetration time of the light across the pellet. The reflectivity of the target can be made negligible as in the present direct drive and indirect drive experiments, and the absorptivity can be increased by one or two orders of magnitude by plasmonic nano-shells embedded in the target fuel. Thus, higher ignition temperature and radiation dominated dynamics can be achieved with the limited initial compression. Here, we propose that a short final light pulse can heat the target so that most of the interior will reach the ignition temperature simultaneously based on the results of RFD. This makes the development of any kind of instability impossible, which would prevent complete ignition of the target.

Golden Nano-Shells – Resonant Light Absorption

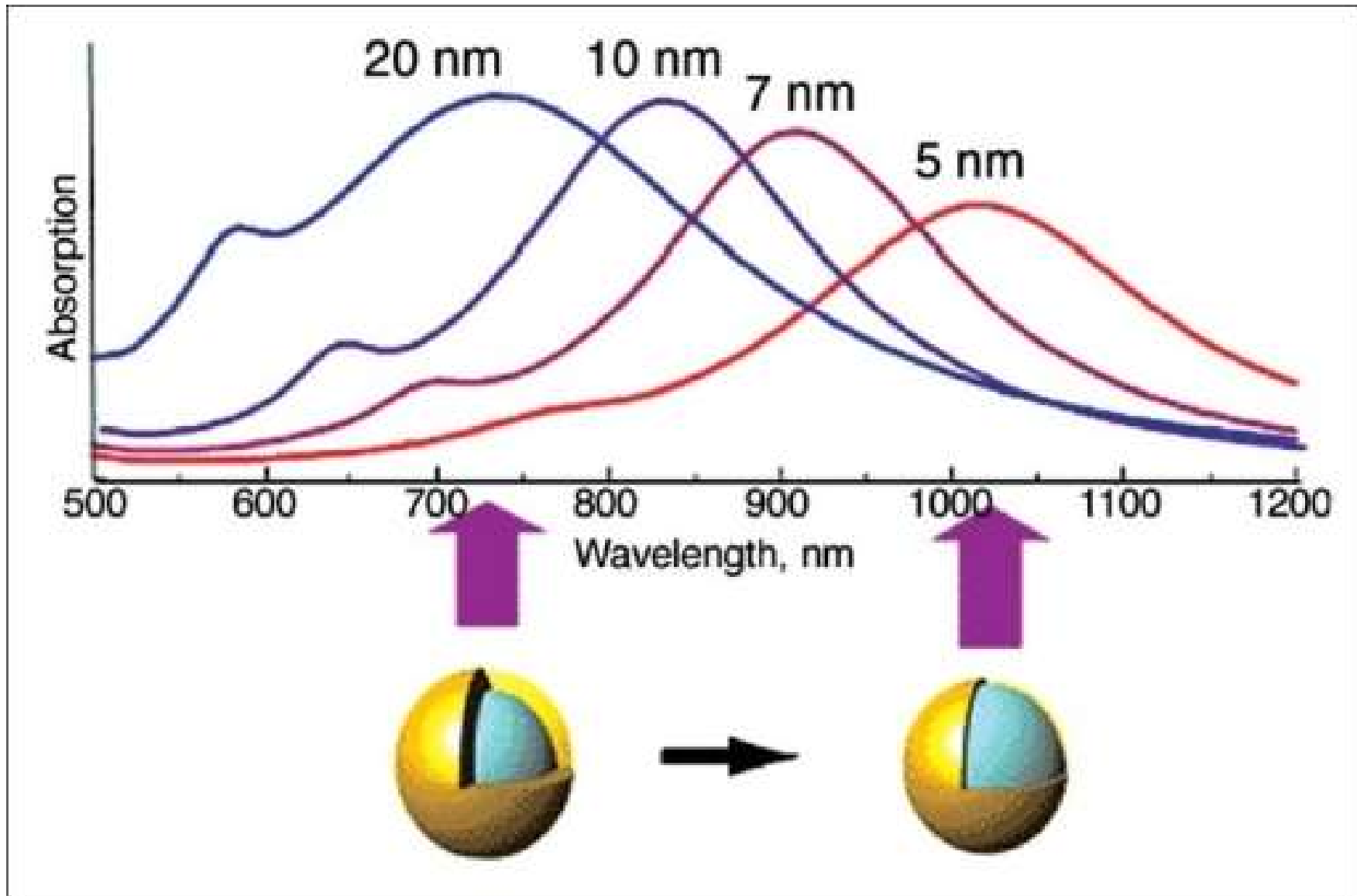

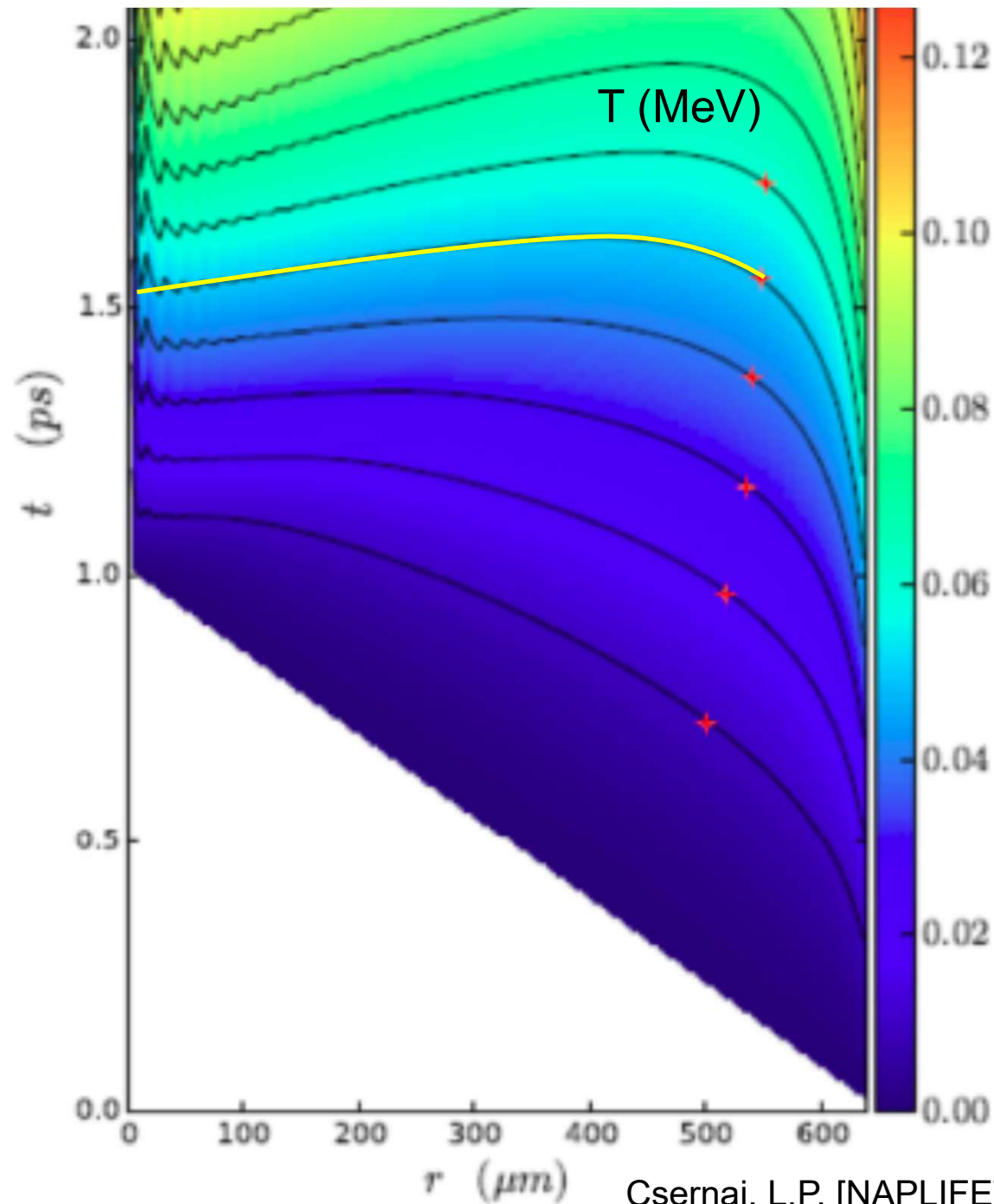

Csernai, L.P. [NAPLIFE]

The absorption coefficient is **linearly** changing with the radius: In the center, $r = 0$, $\alpha_K = 30 \text{ cm}^{-1}$ while at the outside edge $\alpha_K = 8 \text{ cm}^{-1}$.

The temperature is measured in units of $T_1 = 272 \text{ keV}$, and $T_n = n T_1$.

Simultaneous, volume ignition is up to 0.9 R, so 73% of the fuel target!

**How can we realize it
simpler and with less
expense**

Thick coin like flat target & Two beams only

Thickness of the target is: h ...

h depends on pulse energy, ignition energy, target mass, ...

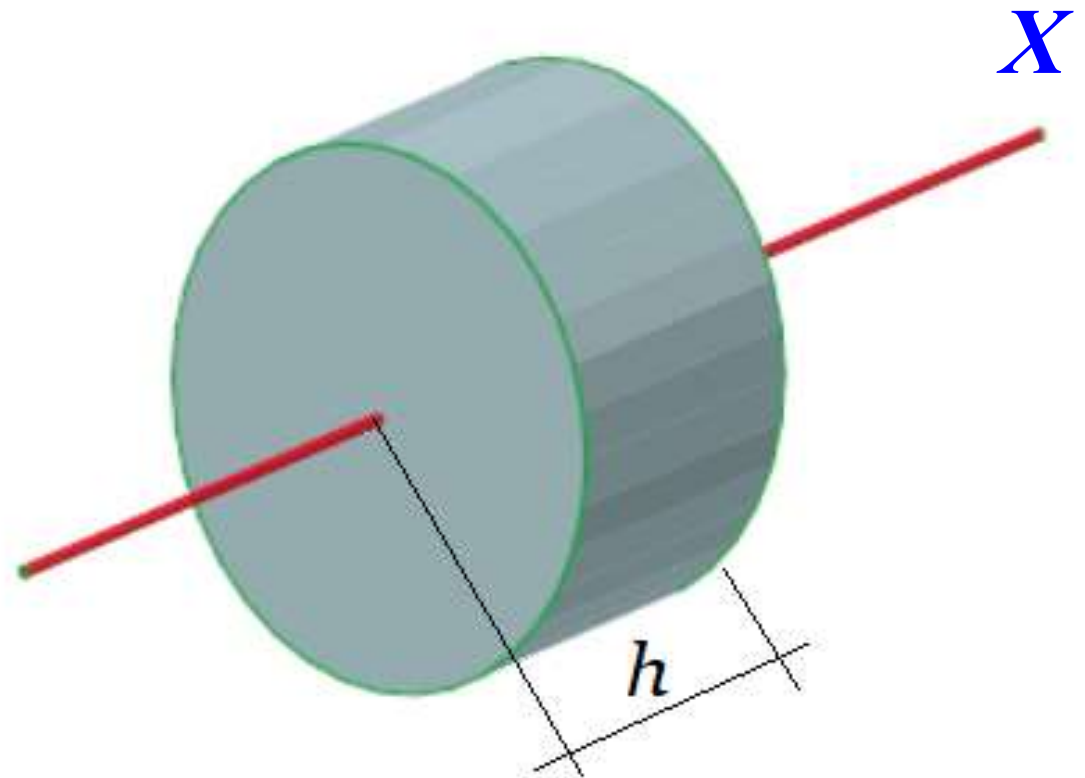

Figure 1: (color online) The target still should be compact to minimize the surface effects. The irradiation is performed along the x -axis from both sides towards the target. The laser beam should be uniform hitting the whole face of the coin shaped target.

[Csernai et al.,
(**NAPLIFE**
Collaboration) *Phys. of
Wave Phenomena*, **28**
(3), 187-199 (**2020**).]

Experimental test of similar configuration @ ShenGuang-II Up, Shanghai :

Nuclear probes of an out-of-equilibrium plasma at the highest compression
Phys. Lett. A 383 (2019) 2285-2289.

G. Zhang^{a,b,*}, M. Huang^c, **A. Bonasera^{d,e,*}**, Y.G. Ma^{f,b,i,*}, B.F. Shen^{g,h,*}, H.W. Wang^{a,b},
W.P. Wang^g, J.C. Xu^g, G.T. Fan^{a,b}, H.J. Fu^b, H. Xue^b, H. Zheng^j, L.X. Liu^{a,b}, S. Zhang^c,
W.J. Li^b, X.G. Cao^{a,b}, X.G. Deng^b, X.Y. Li^b, Y.C. Liu^b, Y. Yu^g, Y. Zhang^b, C.B. Fu^k,
X.P. Zhang^k

4 (up) + 4(down) lasers
Target thickness, h ($3.6\mu\text{m}$ - 1mm)
& radius, R , (150 - $400\mu\text{m}$) were varied.

Total pulse energy 1.2kJ (2ns) for 8 beams.
Shortest (250ps) pulses \rightarrow 100s MeV ions $>$
non-thermal distr. = directed ion acceleration

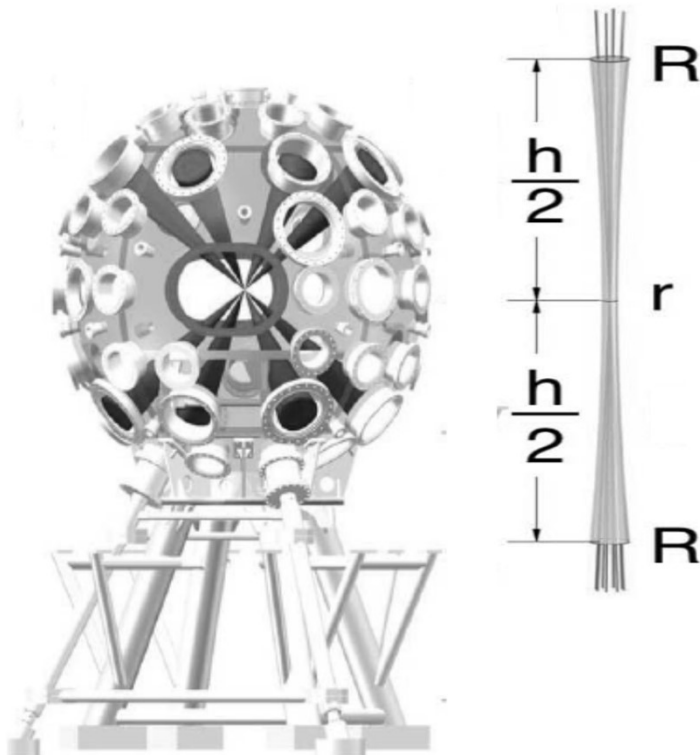

Csernai, L.P. [NAPLIFE]

Typical fusion neutron energies were measured
& used to extract the target density.

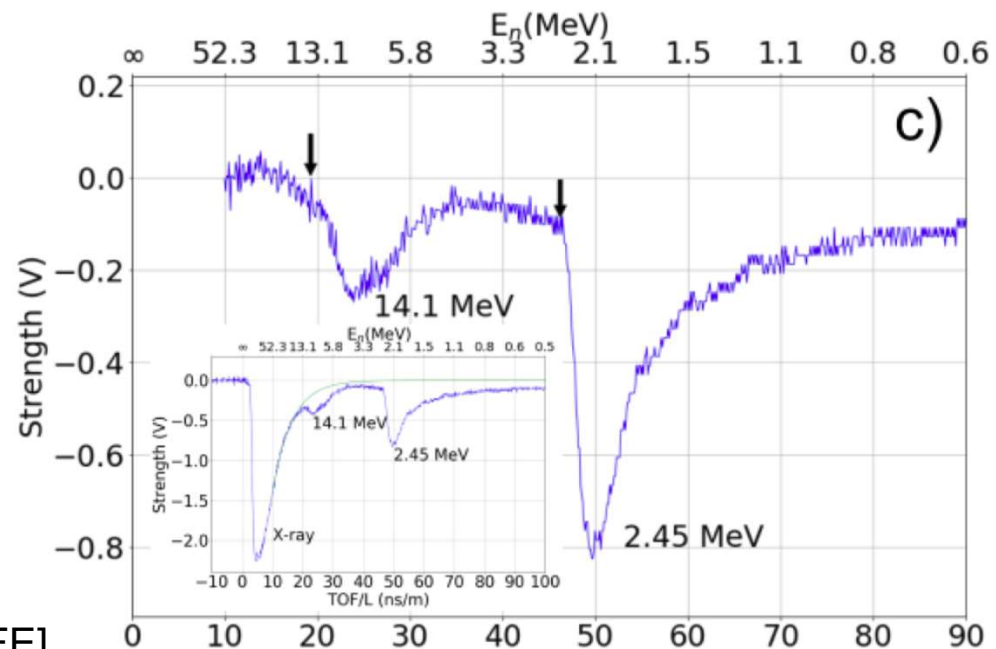

Experimental test of similar configuration @ ShenGuang-II Up, Shanghai :

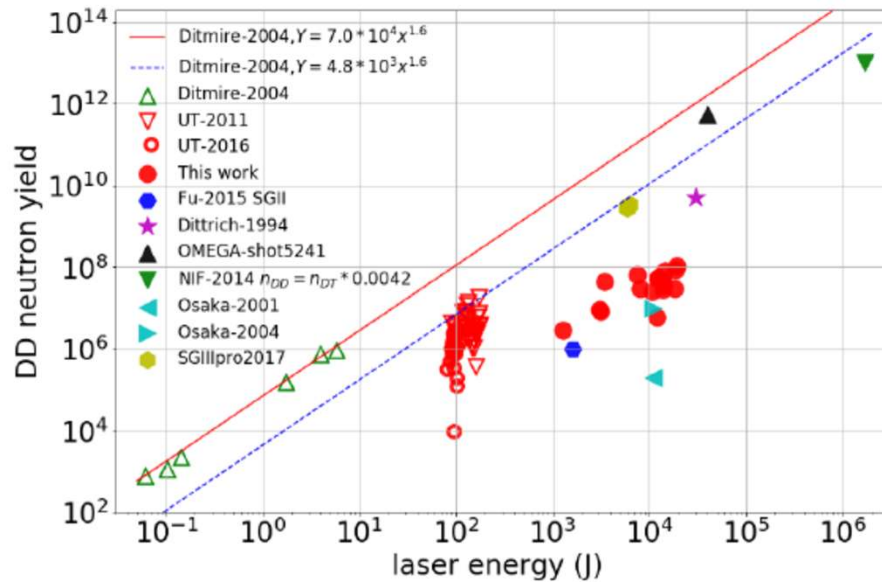

Figure 3: (color online) Fusion yield as function of laser energy. Different experimental results Ditmire-2004[40], UT-2011[20], UT-2016[19], Fu-2015 SGII[45], Dittrich-1994[49], NIF-2014[48], Osaka-2001[46], Osaka-2004[47], OMEGA-shot5241[41] and SGIIpro2017[42] are indicated in the inset.

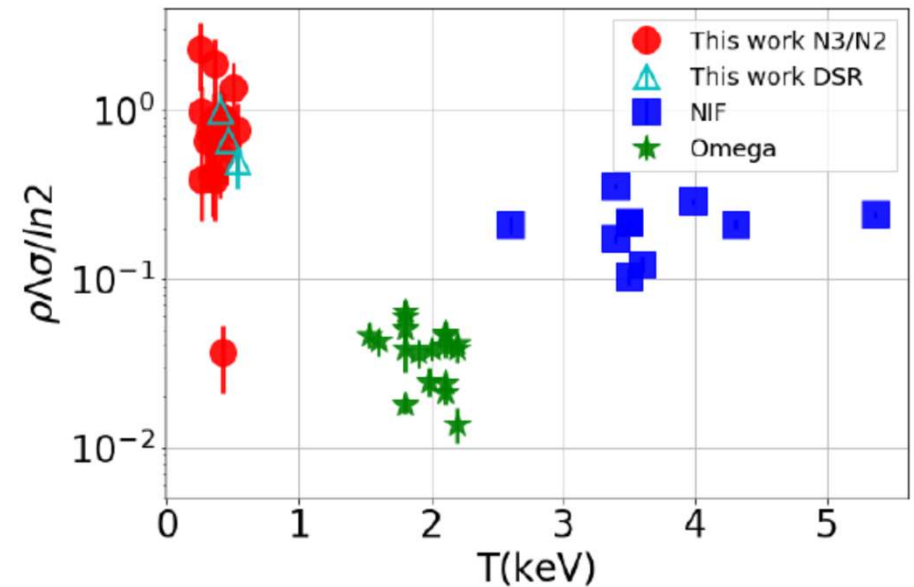
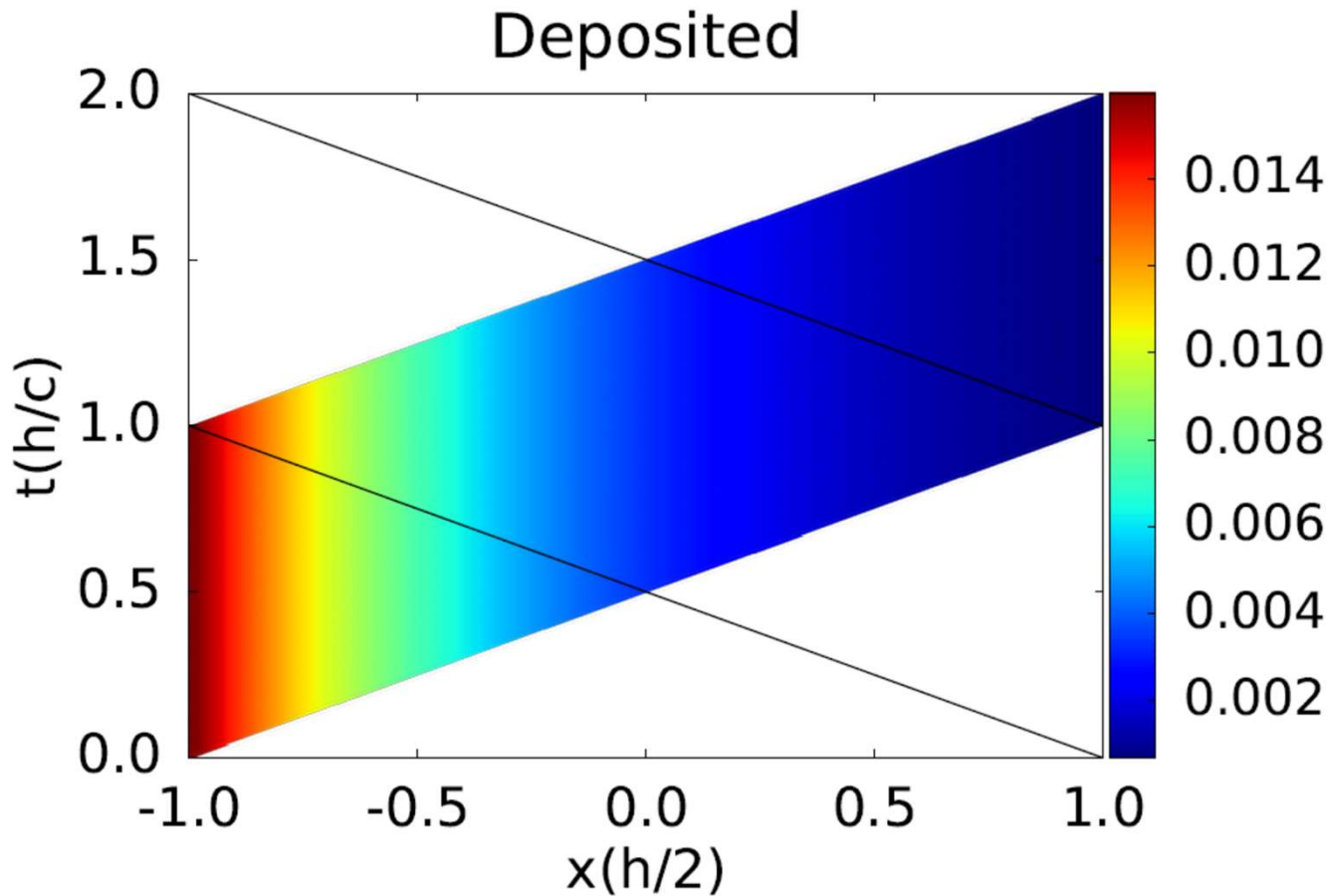

Figure 4: (color online) $\Lambda\rho\sigma/\ln 2$ obtained from eq.(4) vs T from eq.(1). Omega and NIF data are derived from the experiments[25], using the Down Scatter Ratio[23, 21]. Our results using the DSR method (N_4/N_3) are given by the open triangle symbols in good agreement with the N_3/N_2 ratios.

Stimulated by these considerations we decided not to fight non-equilibrium effects but rather enhance them, i.e. study plasmas highly compressed and completely out of equilibrium. A scheme for a colliding

- However,**
- no simultaneous ignition, and**
 - no nano-antennas up to now !**



**Without nano
antennas**

The deposited energy from laser irradiation from one side only. The absorption is constant, this leads to an exponentially decreasing energy deposition, and only a negligibly small energy reaches the opposite end of the target.

Deposited

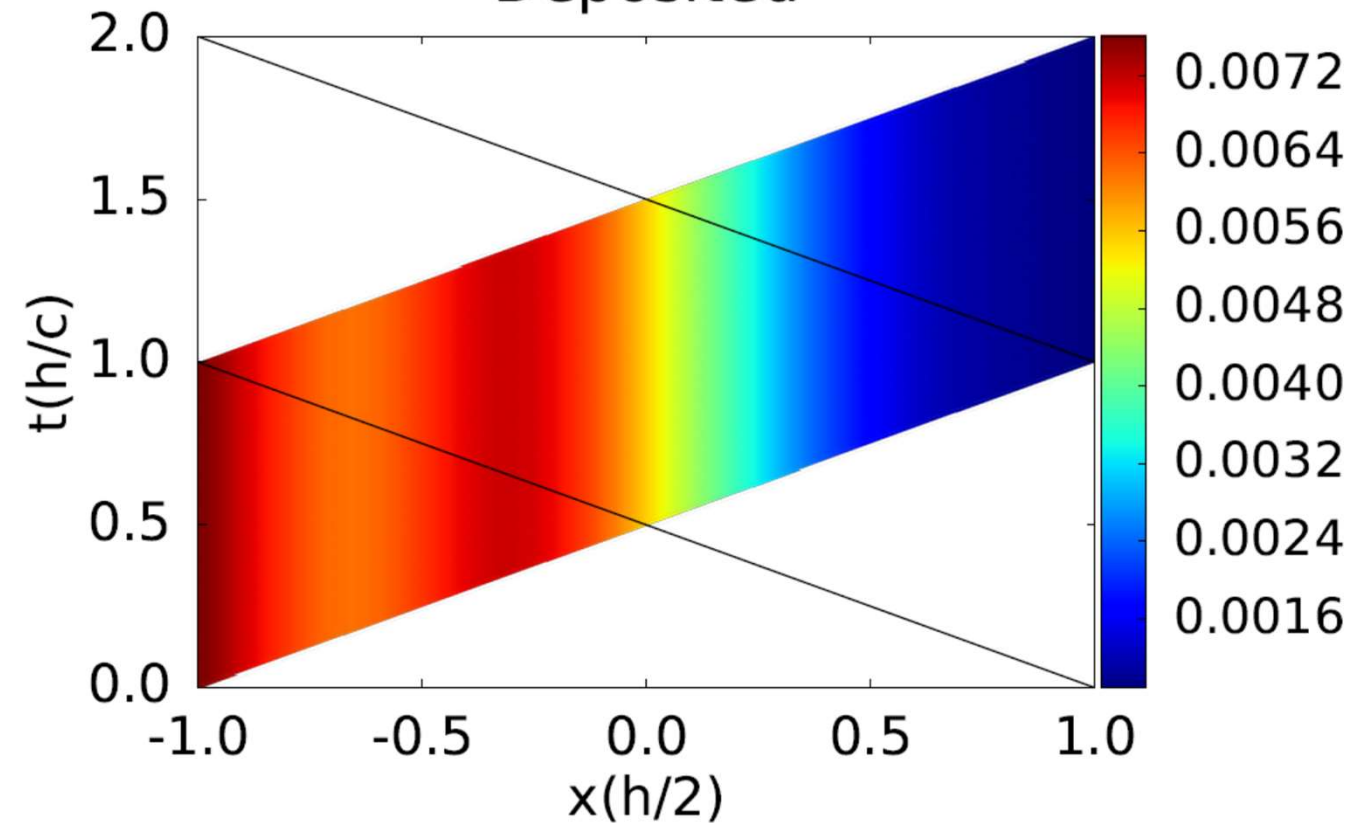

**With nano
antennas**

**The absorptivity is
increased towards
the center, due to the
implanted nano
antennas.**

The deposited energy from laser irradiation from one side only. The absorption is modified by nano antennas so that the absorptivity is increasing towards the middle, so that the deposited energy is constant up to the middle. Then the absorptivity is decreasing, but hardly any energy is left in the irradiation front. Thus again only a negligibly small energy reaches the opposite end of the target.

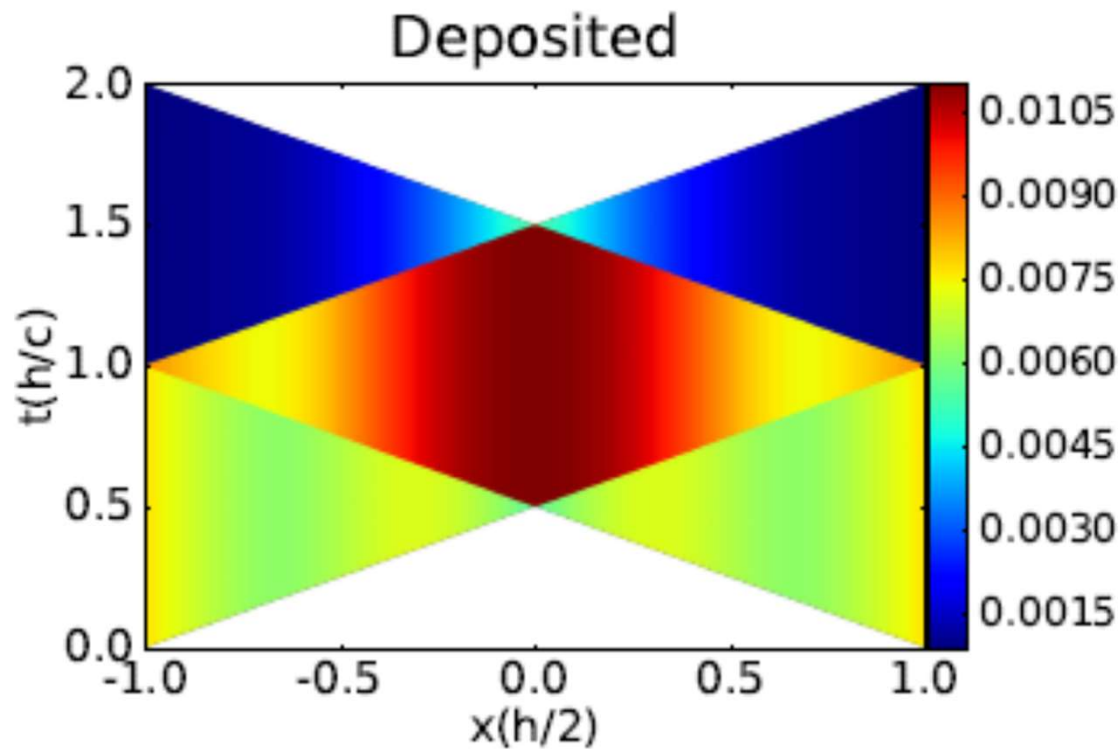

Figure 2: (color online) Deposited energy per unit time in the space-time across the depth, h , of the flat target. The time is measured in units of (h/c) , where c is the speed of light in the material of the target. The irradiation lasts for a period of $\Delta t = h/c$ the time needed to cross the target. The irradiated energy during this time period is Q from one side, so it is $2Q$ from both sides together.

The color code indicates the deposited energy per unit time and unit cross section (a.u.). The deposited length is $\Delta x = c\Delta t$. Note! The absorptivity in this case $\alpha_K \neq \text{const}$. For more details please see Appendix B.

With nano antennas

Irradiation from both sides.

Ignition energy is: Q_i/m

e.g. for DT target: $Q_i/m = 27 \text{ kJ/g}$

→ if we have $Q = 100 \text{ J}$, then we can have a target mass:

$$m_{DT} = Q / Q_i \text{ g} = 3.703 \text{ mg}.$$

Then with m_{DT} and ρ_{DT} given we get the DT-target's volume, V_{DT} and $h_{DT} = 2.67 \text{ mm}$.

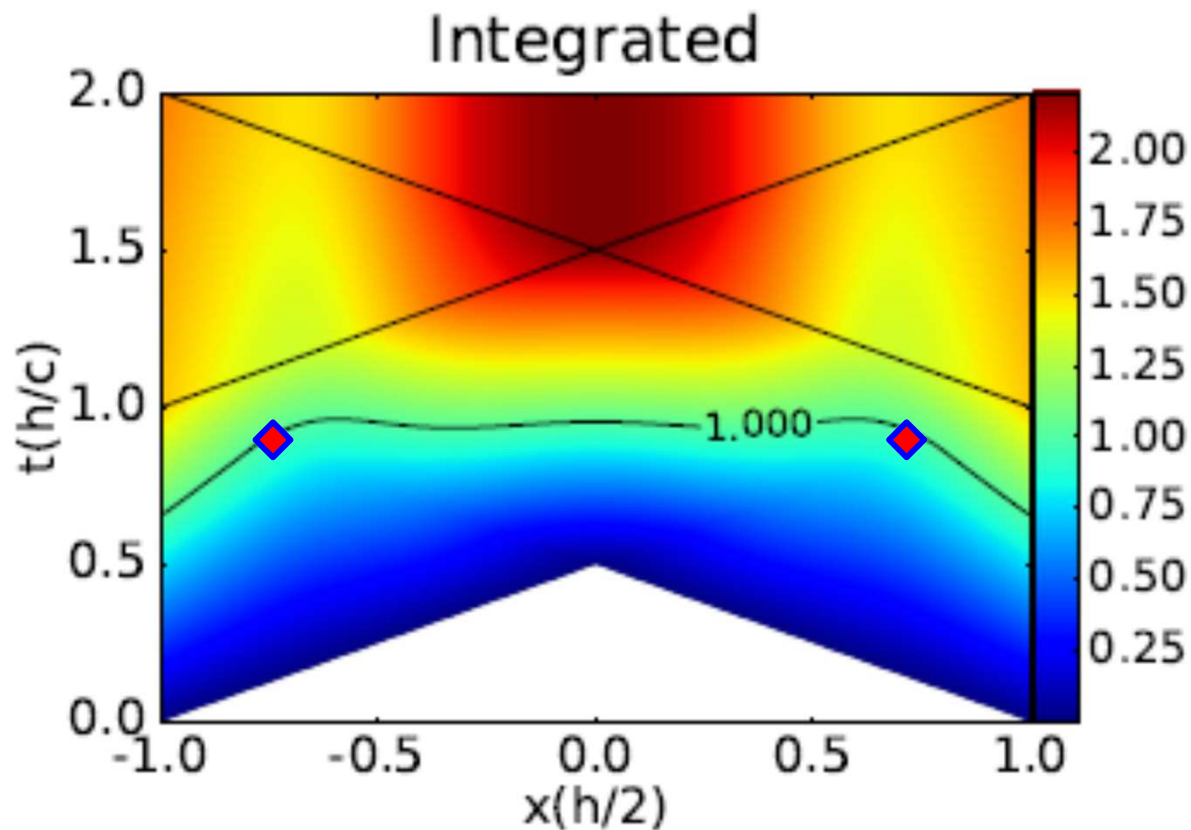

Figure 3: (color online) Integrated energy up to a given time in the space-time across the depth, h , of the flat target. The color code indicates the temperature, T , reached in a given space-time point, in units of the critical temperature, (T_c) . The contour line $T = 1$, indicates the critical temperature, T_c where the phase transition or the ignition in the target is reached. This contour line is almost at a constant time, indicating simultaneous whole volume transition or ignition. The irradiated energy, Q is chosen so that, $1Q$ irradiation will achieve the critical temperature.

Csernai, L.P. [NAPLIFE]

With nano antennas

Ignition is reached at contour line $Q = 1$.

[Csernai et al., (NAPLIFE Collaboration) *Phys. of Wave Phenomena*, **28** (3), 187-199 (2020).]

Simultaneous ignition in the whole target volume → Short Pulse: ELI - ALPS

**Validation tests at lower energies
idea #2 increased absorption via
nano-antennas**

Wigner RCP, Budapest



Ti:Sa Hydra Laser: 30mJ, 10Hz, 40fs **[P. Racz et al., Wigner RCP]**

Csernai, L.P. [NAPLIFE]

Target Modeling and Manufacturing

→ Attila Bonyár's talk

Target materials, absorptivity, implanted nanoantennas

Cyclic olefin copolymer (COC)

Urethane dimethacrylate (UDMA) - 75%

triethylene glycol dimethacrylate (TEGDMA) - 35%

Flat layered target

One layer thickness: 3 μm

Seven layers: 21 μm

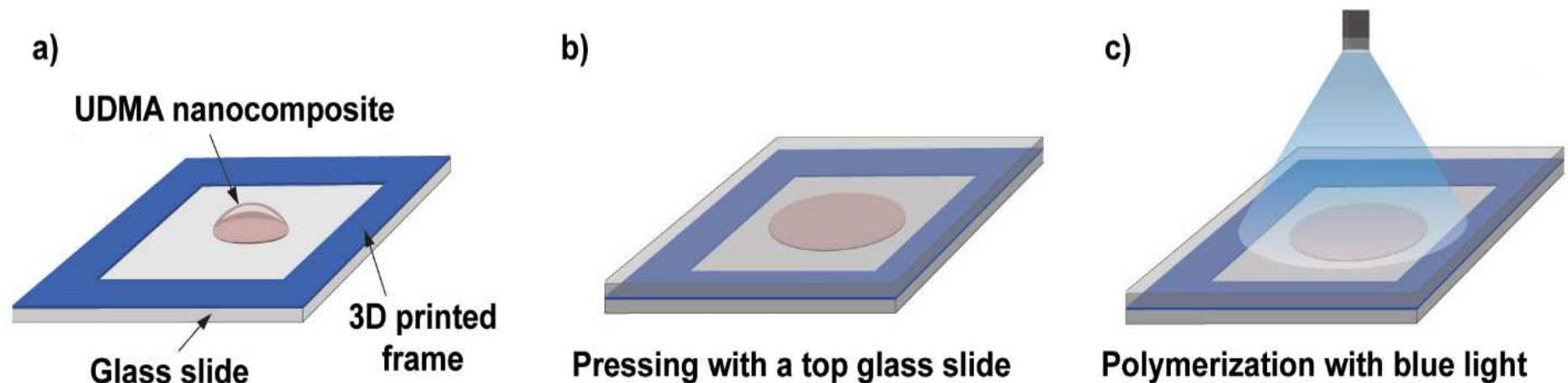

[A. Bonyar et al., In preparation]

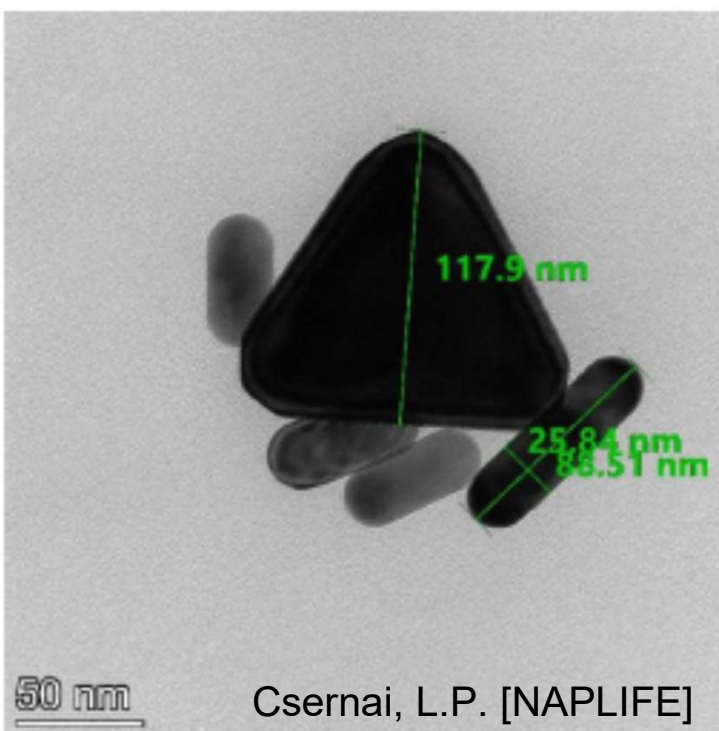
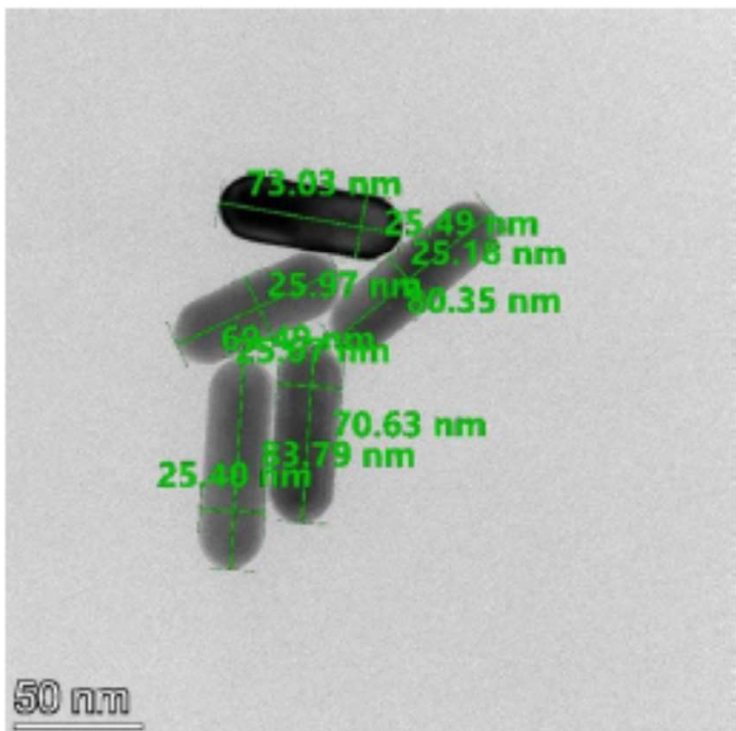
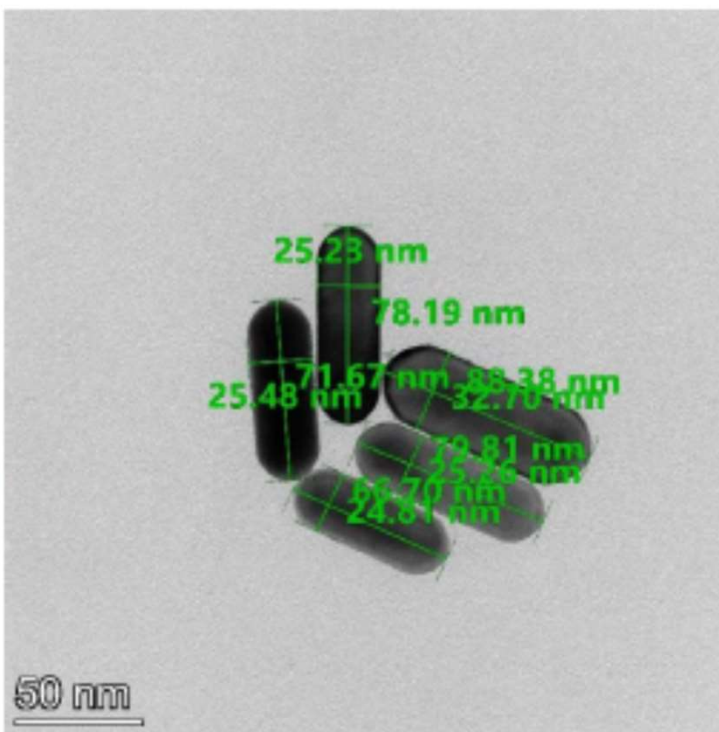
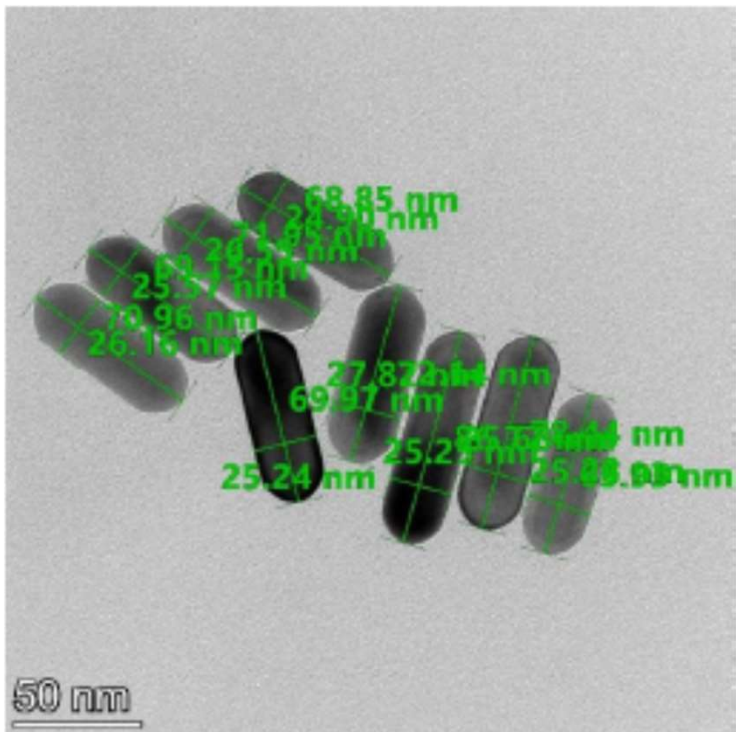

Transmission Electron-microscopy photos of 75x25 nm gold nano-rod antennas

[Judit Kámán, A. Bonyár et al. (NAPLIFE Collab.), Gold nanorods ..., 10th ICNFP 2021, **Kolymbari**]

Csernai, L.P. [NAPLIFE]

Experimental and theoretical absorbance spectra of 75x25 nm and 85x25 nm gold nanorods [M. Csete et al.]

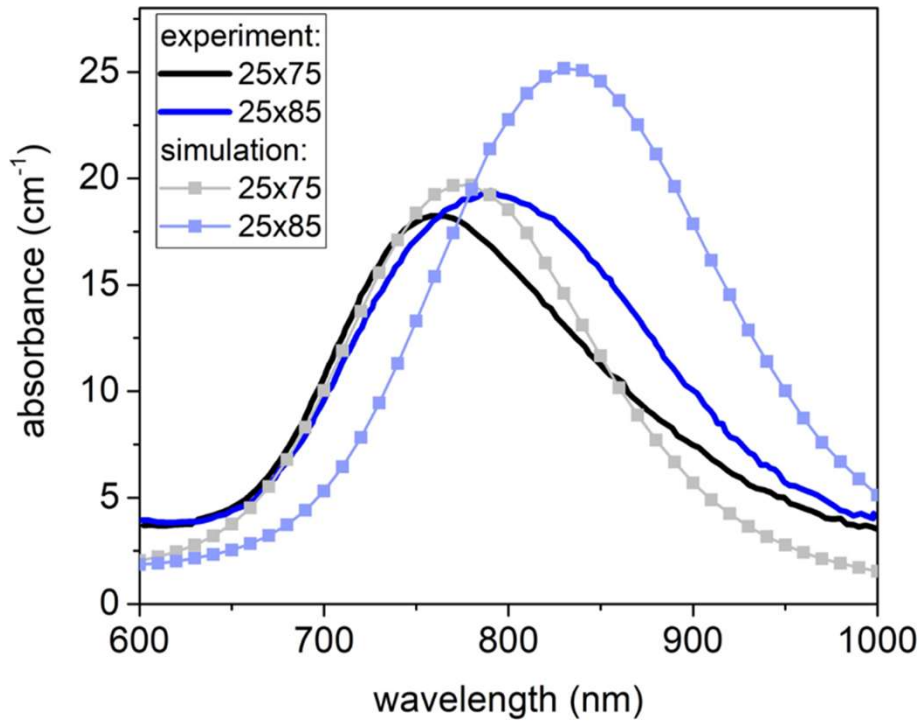

resonance	25x75 nm	25x85 nm
experiment	761 nm	791 nm
simulation	770 nm	830 nm

FWHM	25x75 nm	25x85 nm
experiment	183 nm	204 nm
simulation	164 nm	186 nm

absorbance	25x75 nm	25x85 nm
experiment	16.5 cm ⁻¹	19.5 cm ⁻¹
simulation	19.7 cm ⁻¹	25.2 cm ⁻¹

realistic size distribution

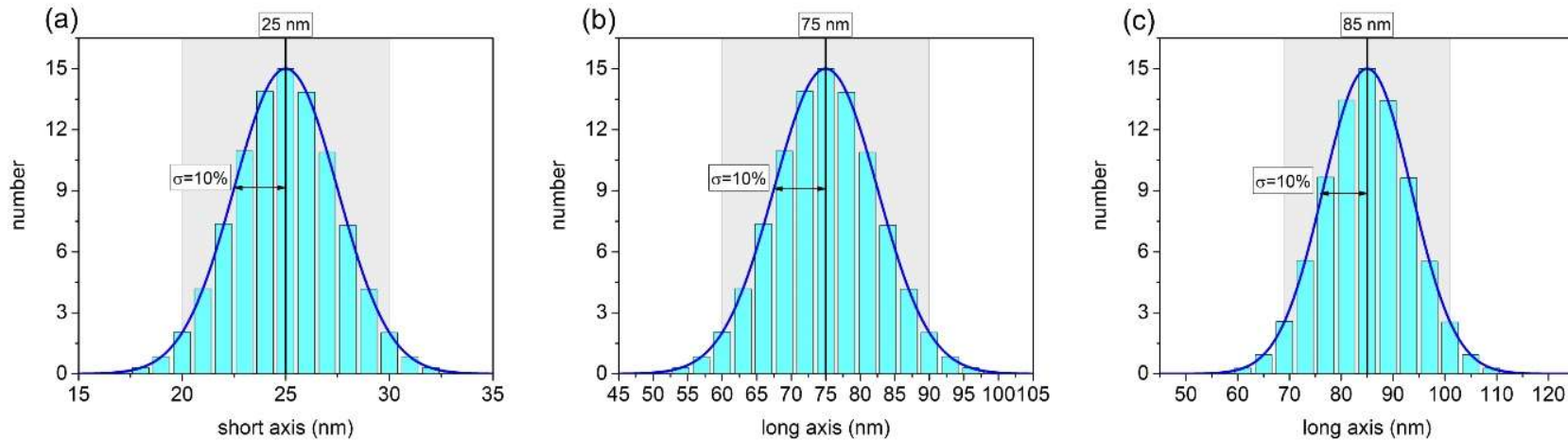

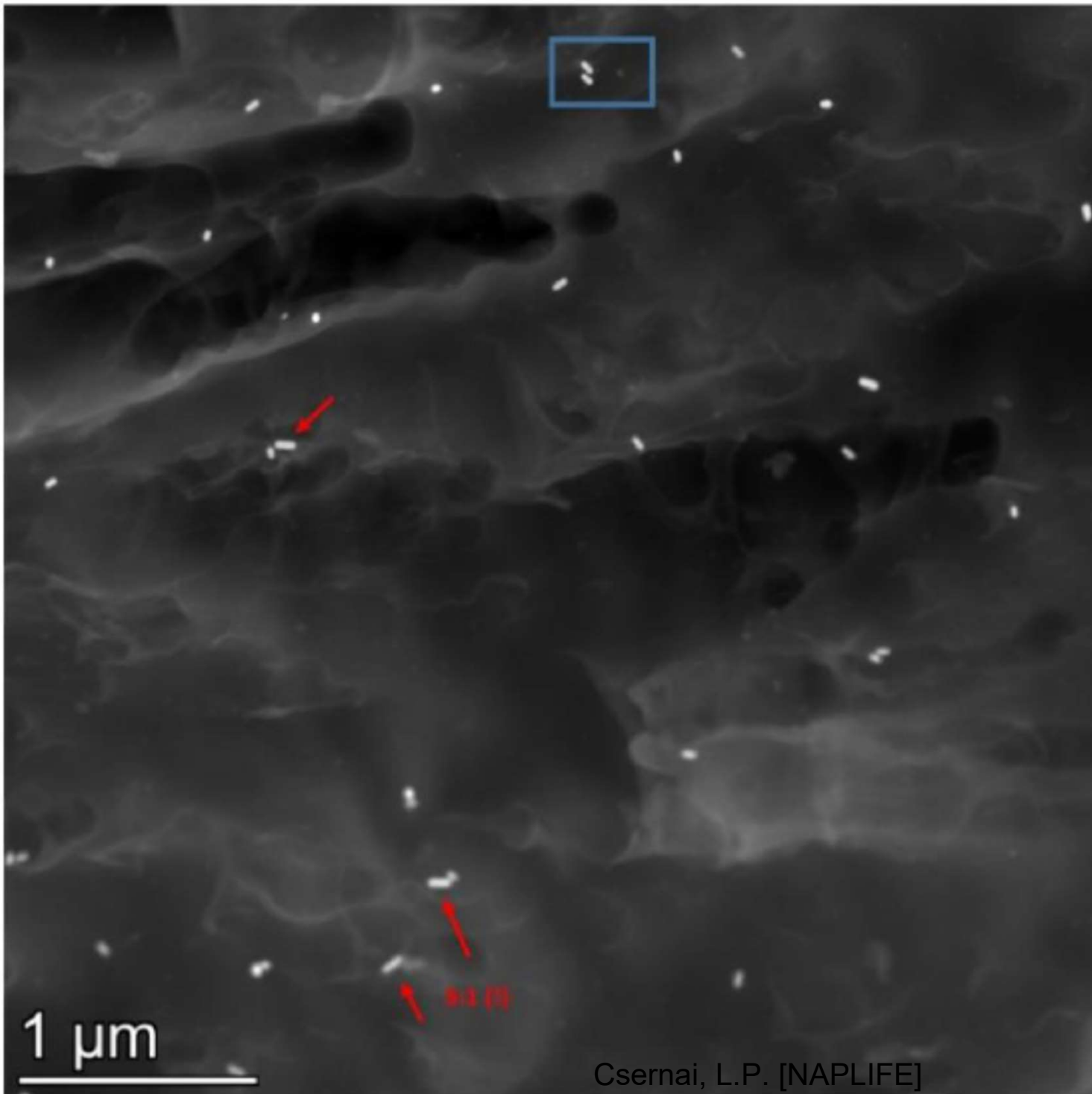

TEM Photo of
~uniformly
implanted
nanorod
antennas in
UDMA target
polymer. The
density is
 $9-20 / \mu\text{m}^3$

[**Judit Kámán, A. Bonyár** et al.
(NAPLIFE Collab.),
Gold nanorods ...,
10th ICNFP
2021, **Kolymbari**,
Crete, Greece, 30
August 2021.]

Nano-particle absorption

The target absorptivity is increased via core-shell type plasmonic nano-shells. Calculations via solving the Maxwell equations, and evaluating the ohmic heating were performed using the COMSOL simulation package.

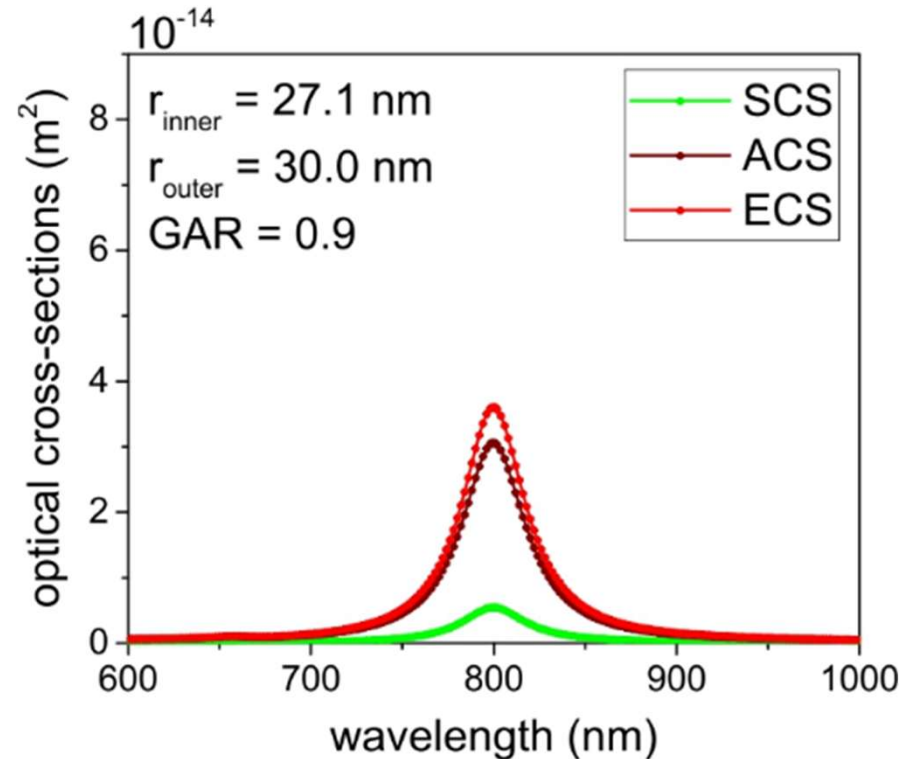
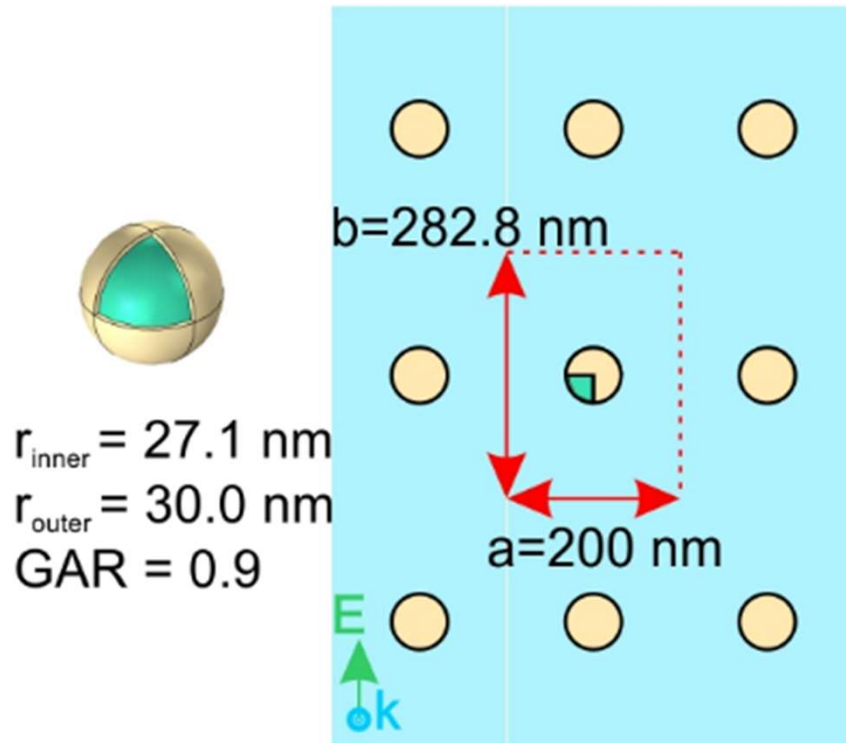

1 ps laser pulse length, $\lambda = 800 \text{ nm}$, one-sided & two-sided irradiation tested, 85-100 % absorption in the target length h .

Nano-antenna shapes, layer configurations, layer distribution varied & analyzed.

[M. Csete, et al., U. Szeged, HU <https://doi.org/10.1007/s11468-021-01571-x>
10.3103/S1541308X20030048]

Layered target with variable light absorption

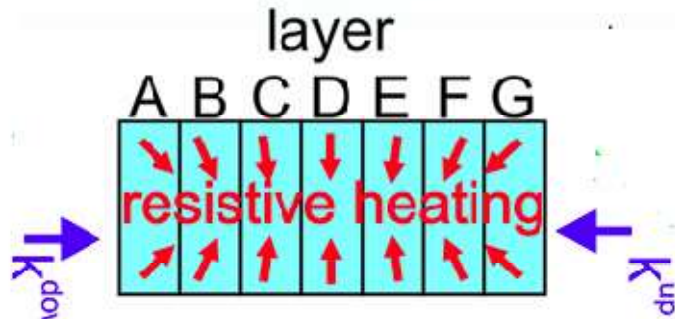

Representative uniform & Gaussian number density distributions of (d) 70 oriented nanorods, in a $1 \times 1 \times 21 \mu\text{m}^3$ supercell of UDMA polymer target, with random location distribution.

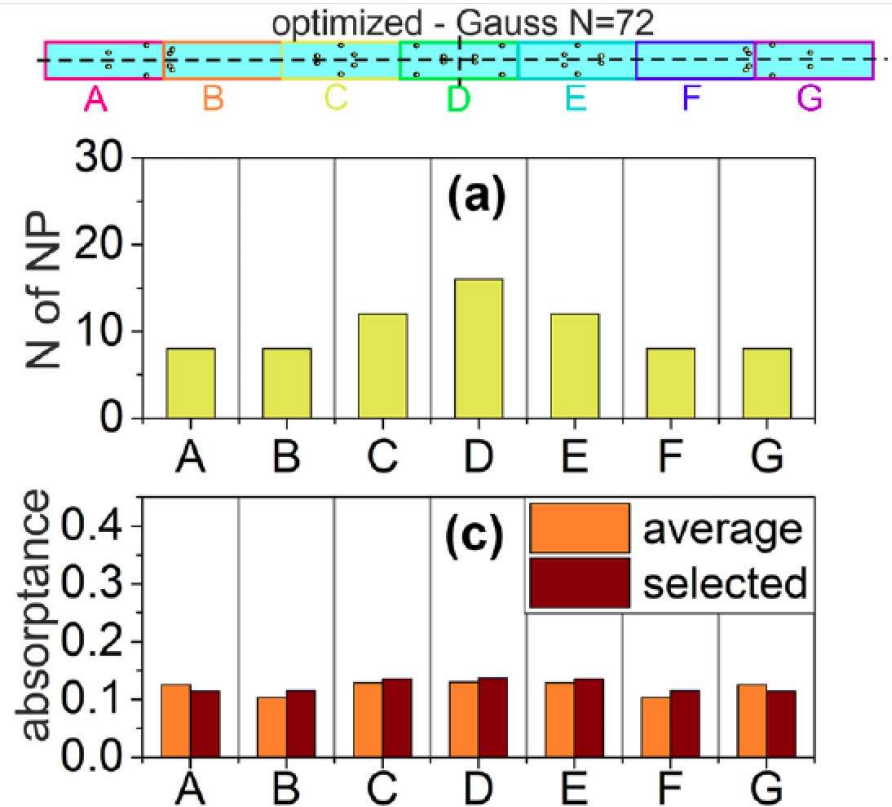

Plasmonics (2022) 17:775–787

<https://doi.org/10.1007/s11468-021-01571-x>

Comparative Study on the Uniform Energy Deposition Achievable via Optimized Plasmonic Nanoresonator Distributions

Mária Csete¹ · András Szenes¹ · Emese Tóth¹ · Dávid Vass¹ · Olivér Fekete¹ · Balázs Bánhelyi² · István Papp^{3,4} · Tamás Bíró³ · László P. Csernai^{3,4,5} · Norbert Kroó^{3,6}

[M. Csete, A. Szenes, E. Tóth, D. Vass, O. Fekete, B. Bánhelyi, T. S. Bíró, L. P. Csernai, N. Kroó: „Comparative study on the uniform energy deposition achievable via optimized plasmonic nanoresonator distributions“, Plasmonics (2022), 17: 775-787; <https://doi.org/10.1007/s11468-021-01571-x>.]

Effect of Short Pulse Laser Beams on target

(N.K.*)

[Bonyár, Kroó, et al.]

Without nanorods(30x)

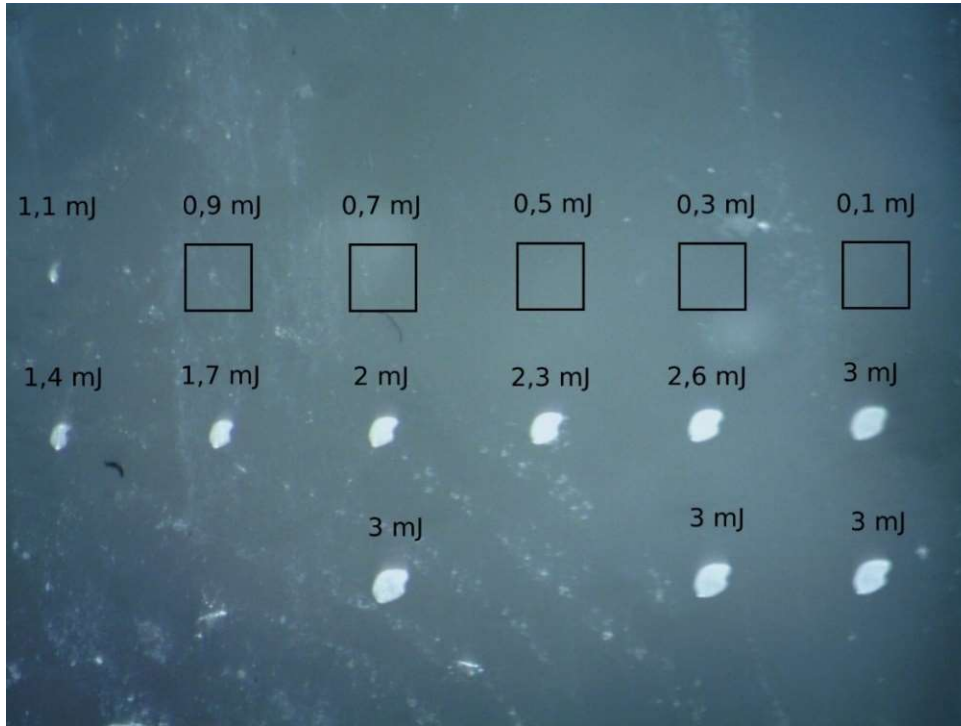

With nanorods (40x)

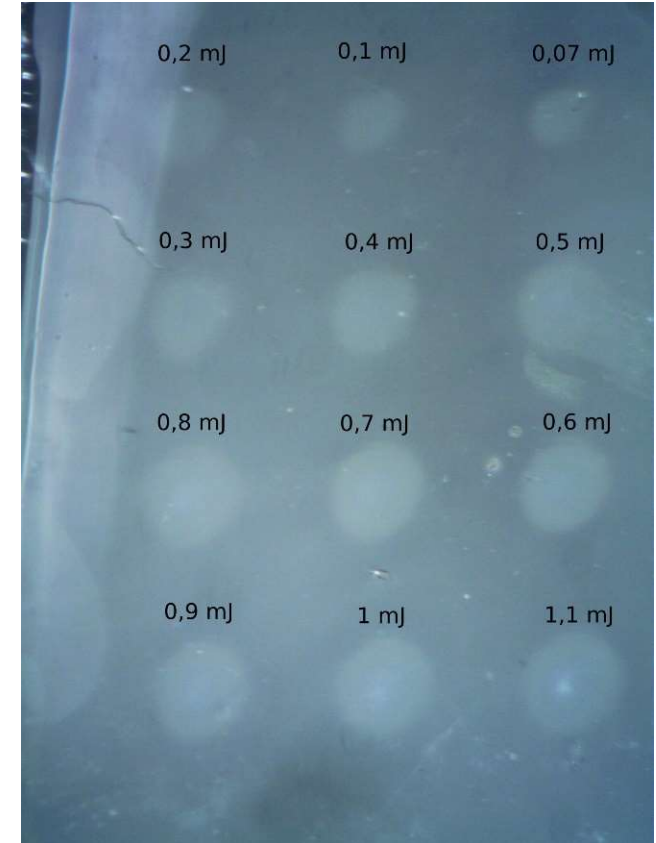

Thickness:
~30 μ to 40 μ

300 fs long laser pulses

Focus: 85 μ diameter
Pulse length: 300fs
Max Intensity ~4. 10¹⁴W/cm²

Laser

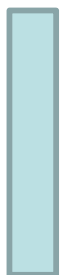

Csernai, L.P. [NAPLIFE]

Plasma absorption

$A = 1 - R$

$I < 3 \times 10^{13} \text{ W cm}^{-2}$, A is almost polarization independent & obeys Fresnel laws, as IB is dominant

• at higher intensities, there is a clear polarization dependence of absorption

• the difference in absorption should account for extra absorption mechanisms, which are polarization dependent

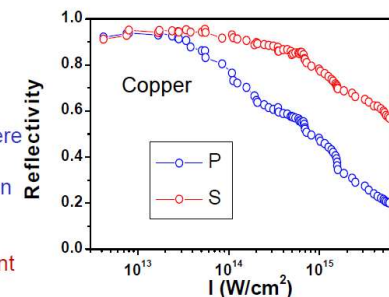

R vs I at 45°

TIFR data

Laser pulse length: 300 fs
 Ti:Sa laser: $\lambda=800\text{nm}$, $\sim 1.55\text{eV}$

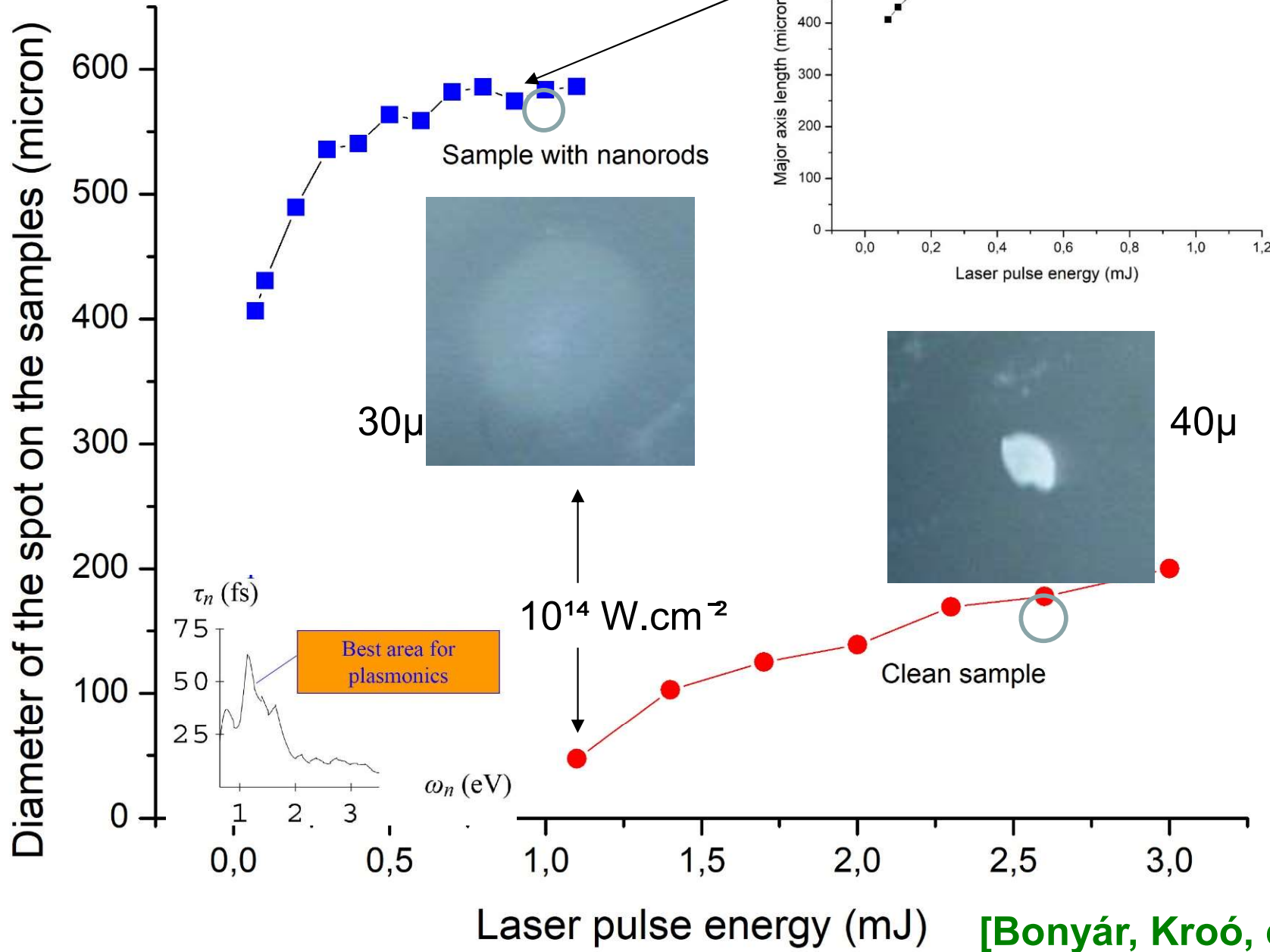

Large plasmonic gain

Laser pulse energy (mJ)

[Bonyár, Kroó, et al.]

Csernai, L.P. [NAPLIFE]

37

Nanorod antenna properties

25x75 nm & 25x130 nm antennas, resonant for $\lambda=795$ nm, in UDMA.

[M. Csete et al. [NAPLIFE], Plasmonics 2022]

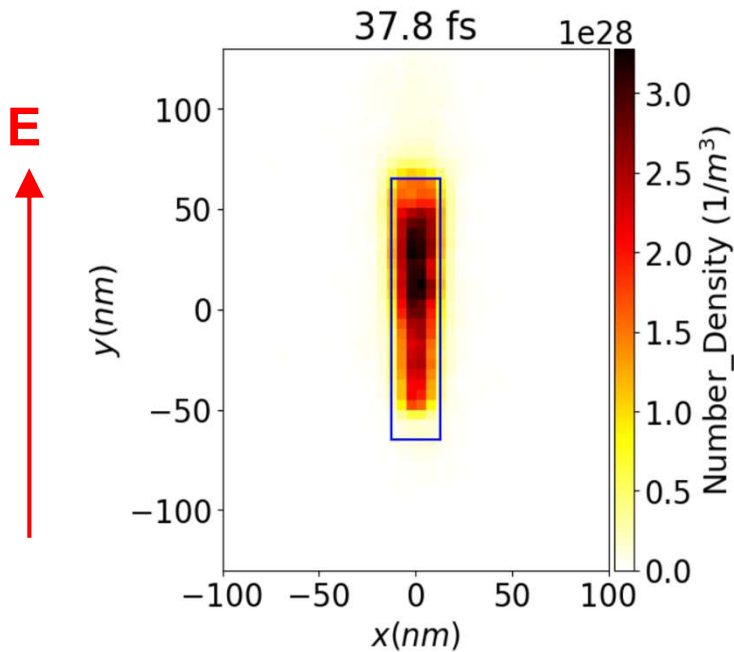
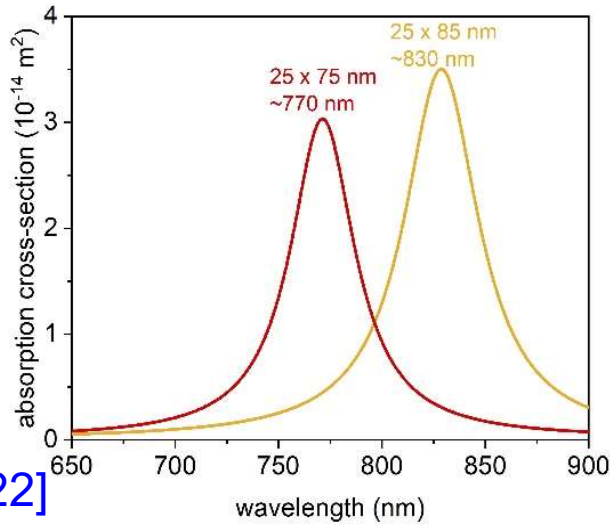

ρ_e for 25x130 nm antennas, in vacuum. EPOCH

[I. Papp et al. (NAPLIFE), Submitted PRX Energy]

Resilience

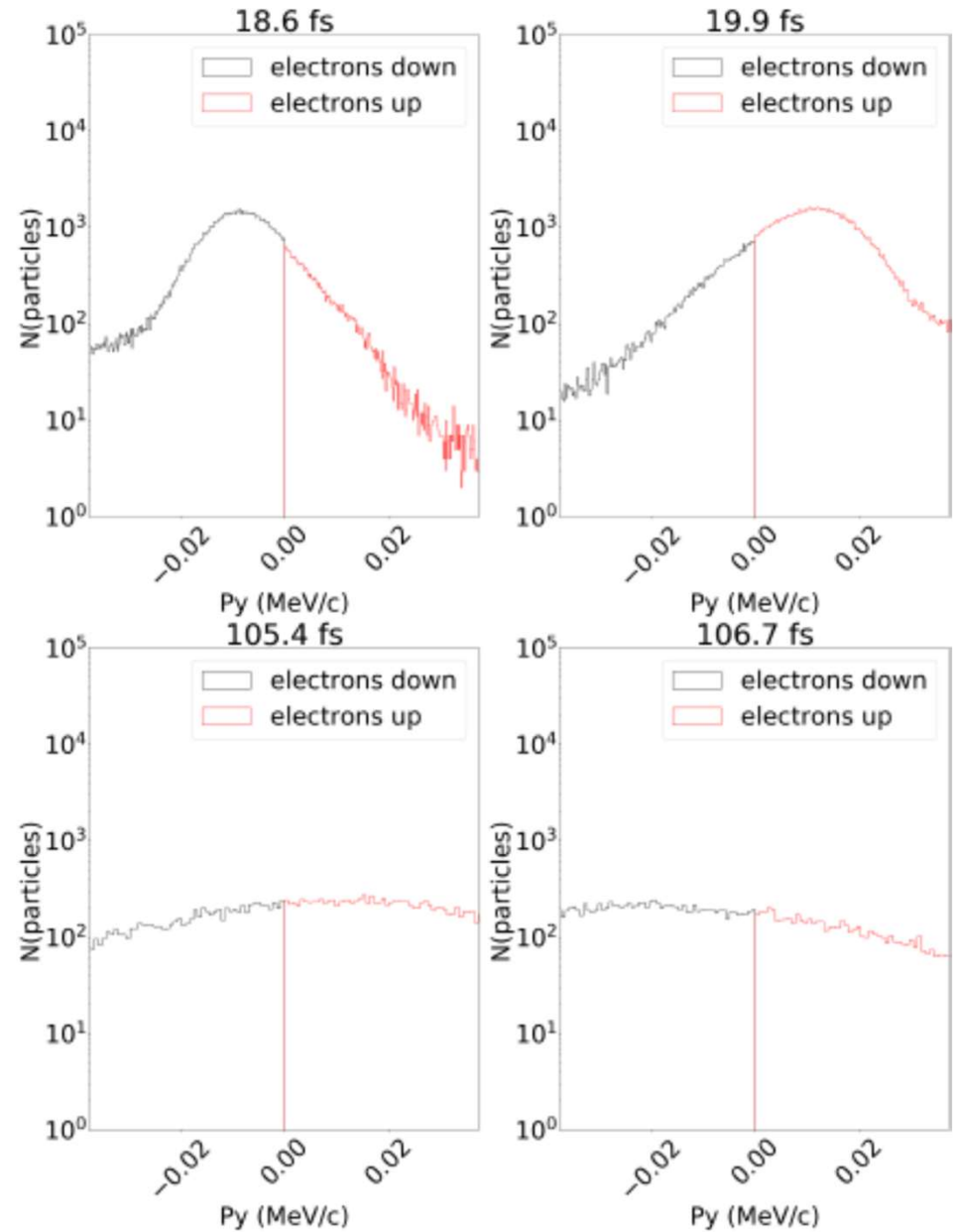

Intensity: $I = 4 \cdot 10^{15} \text{ W/cm}^2$

Csernai, L.P. [NAPLIFE]

Resilience of Nanorod Antenna with EPOCH/PIC

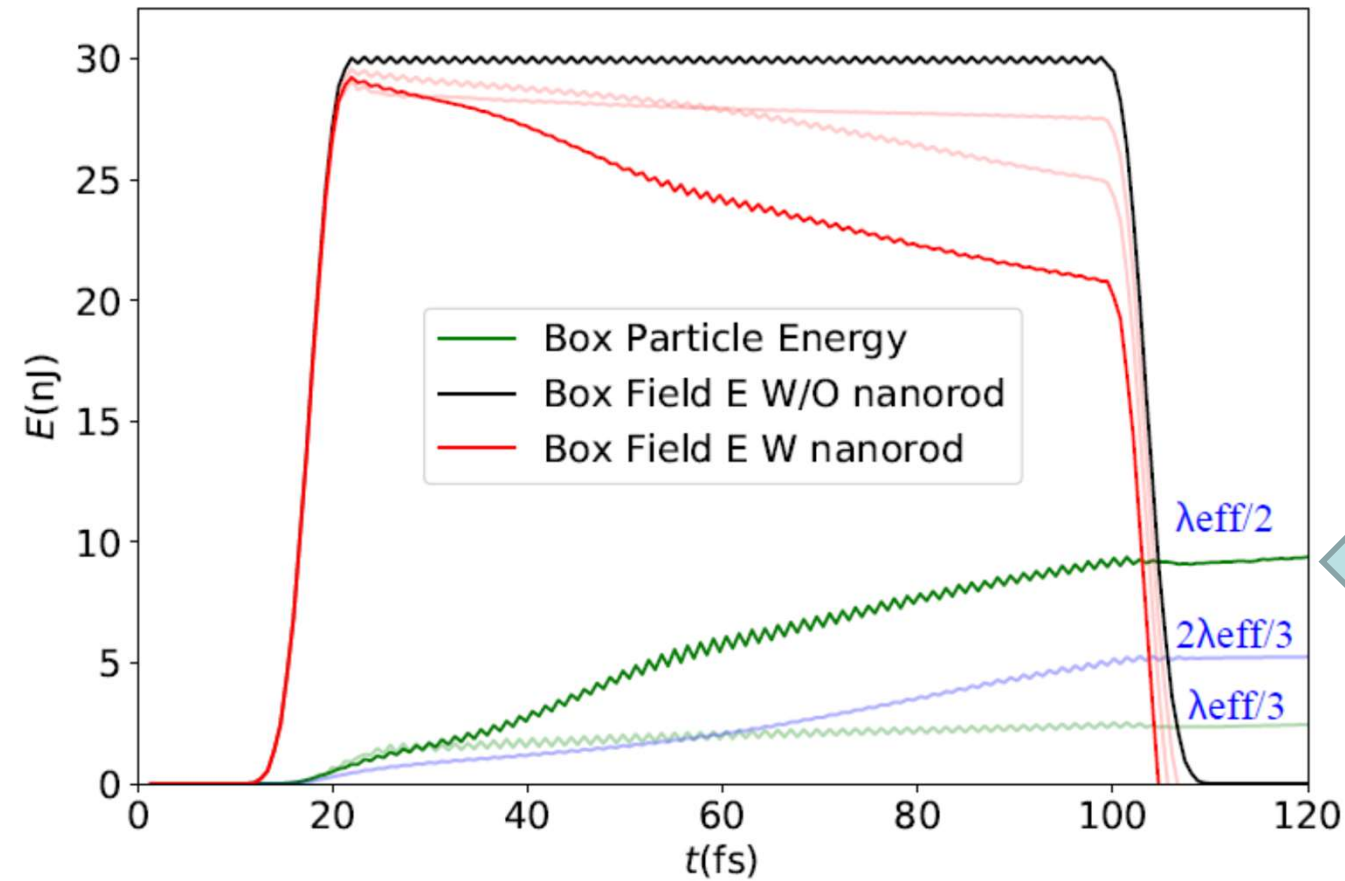

Calculation Box (CB):
 $530 \times 530 \times 795$ nm
 $\lambda = 795$ nm

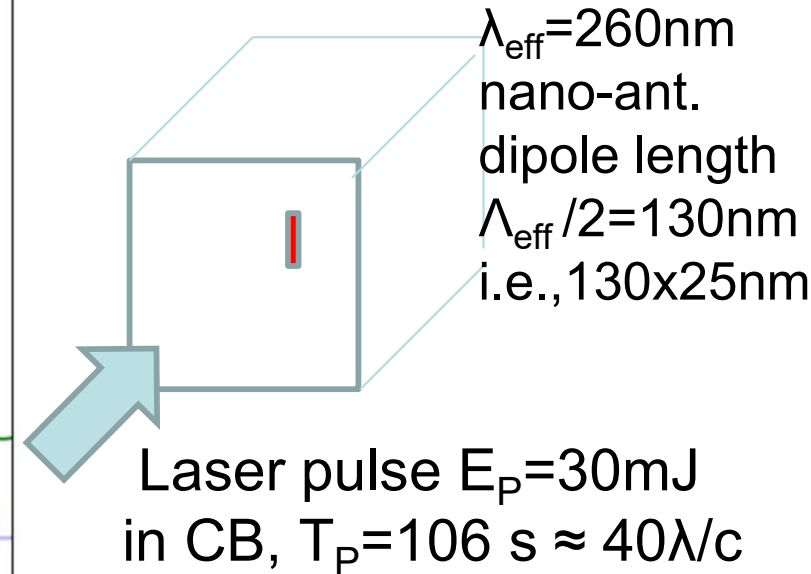

The nanorod antenna has a light absorption cross section, which is nearly 28.5 times bigger than its geometrical cross section

[I. Papp et al. (NAPLIFE Coll.) Submitted to PRX Energy]

Csernai, L.P. [NAPLIFE]

39

Resilience of Nanorod Antenna with COMSOL

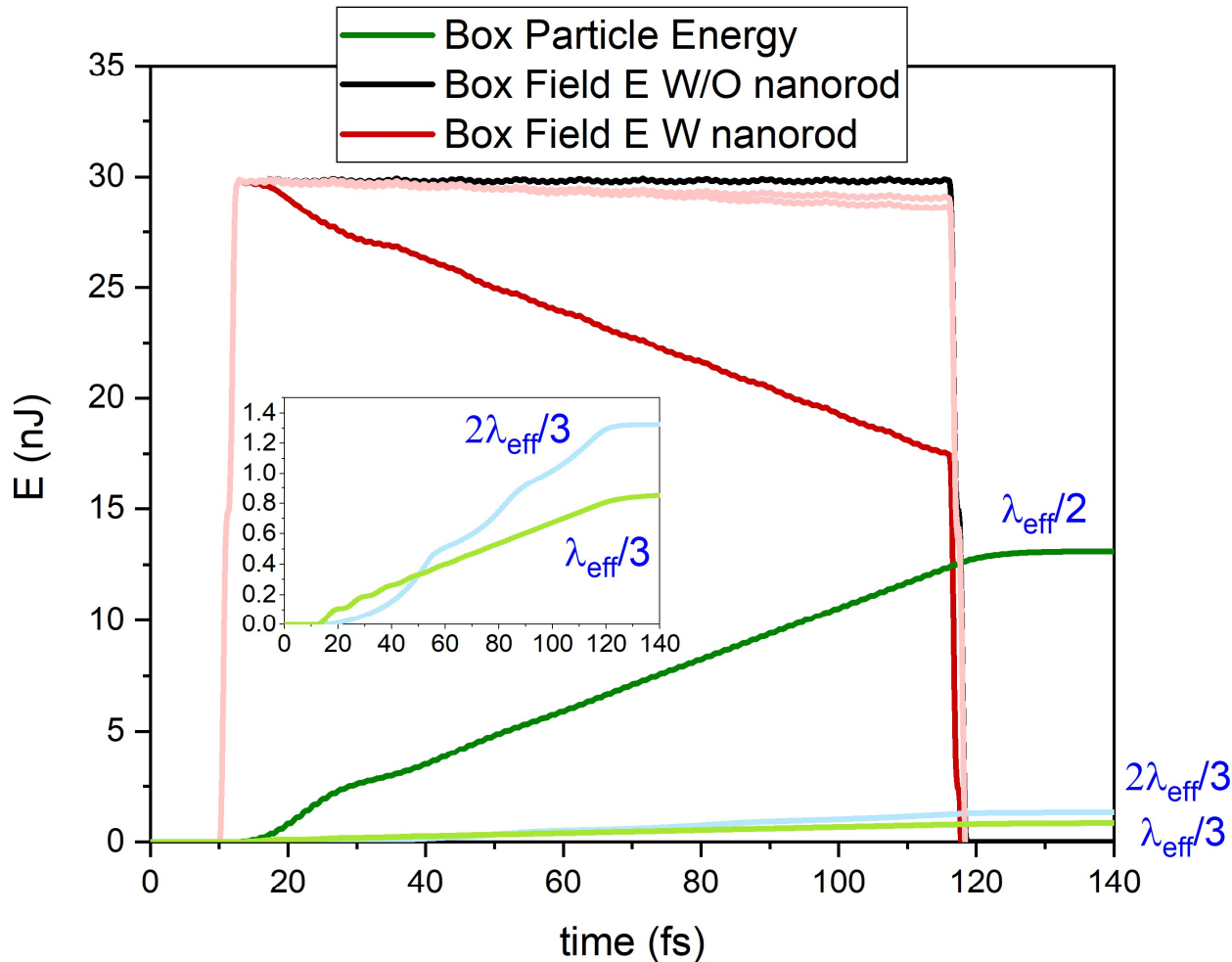

FEM computations with the same model parameters

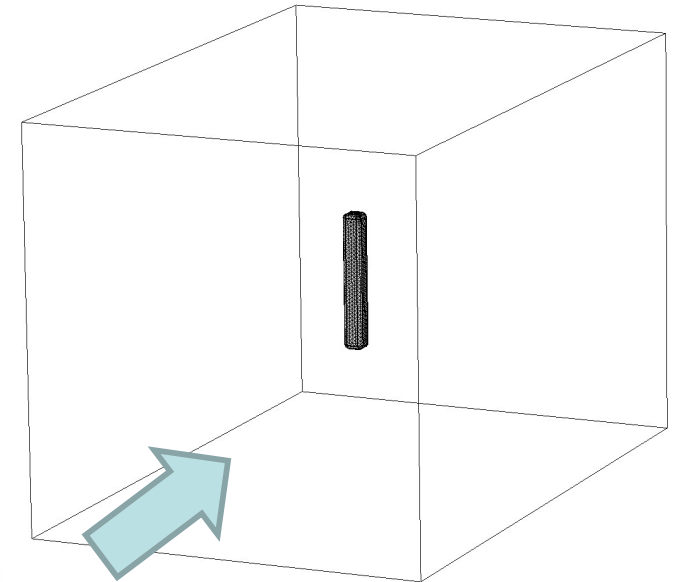

Good qualitative agreement between FEM and EPOCH/PIC methods

Quantitative difference:

the hydrodynamic model of the electron plasma (FEM) predicts a sharper resonance than the kinetic model (EPOCH/PIC)

Validation tests at lower energies
idea #1 Simultaneous (time-like)
transition (ignition)



Two opposing beams

Validation tests – Target manufacturing

Two basic principles are tested on non-fusion material targets at low energies

- Implanted with nano-antennas → Amplified absorption ✓
- Multilayer targets → Simultaneous Ignition (in progress)

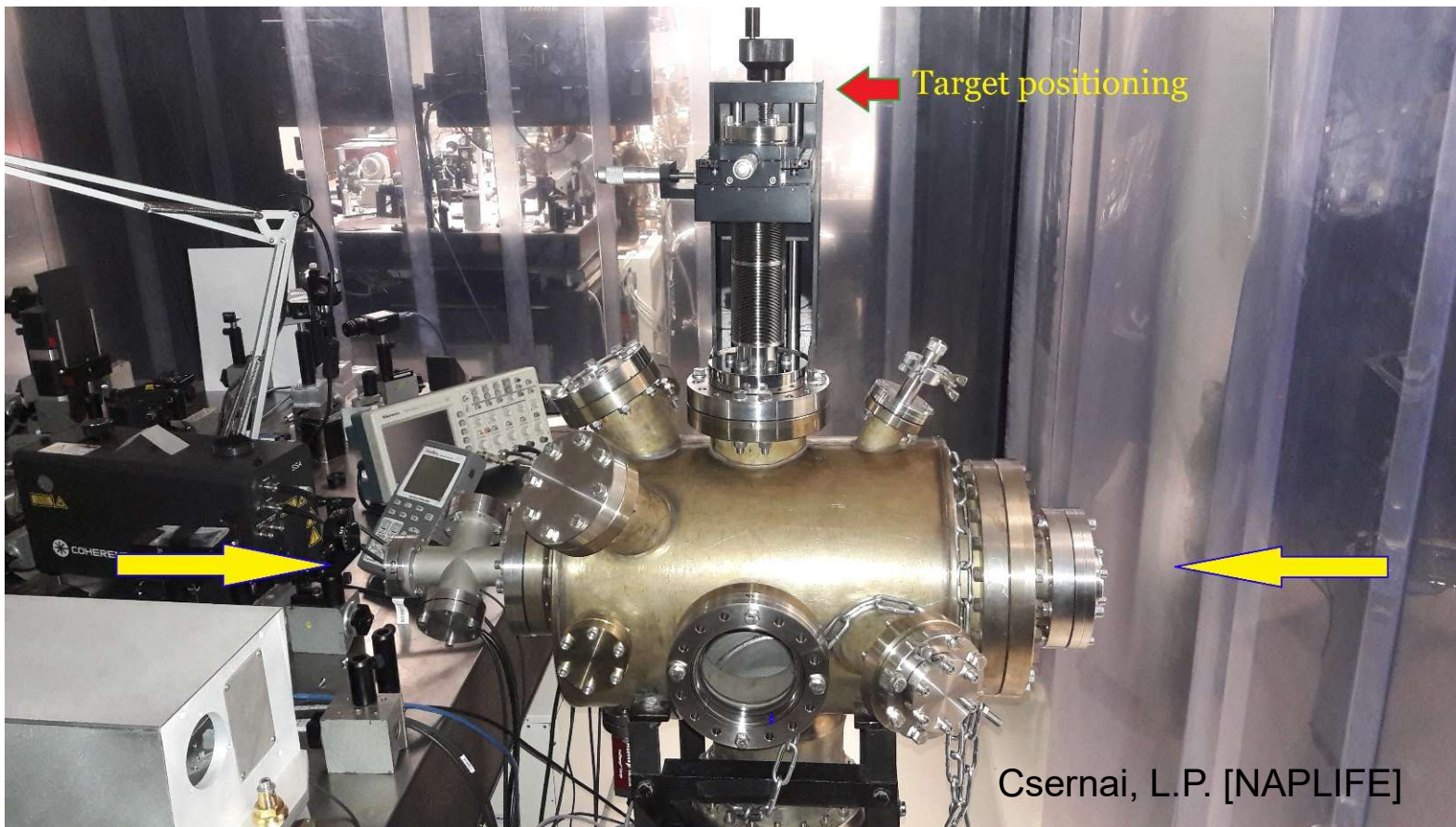

[M. Csete,
A. Bonyár,
I. Papp,
P. Rácz,
et al.]

In preparation



Multilayered fuel target

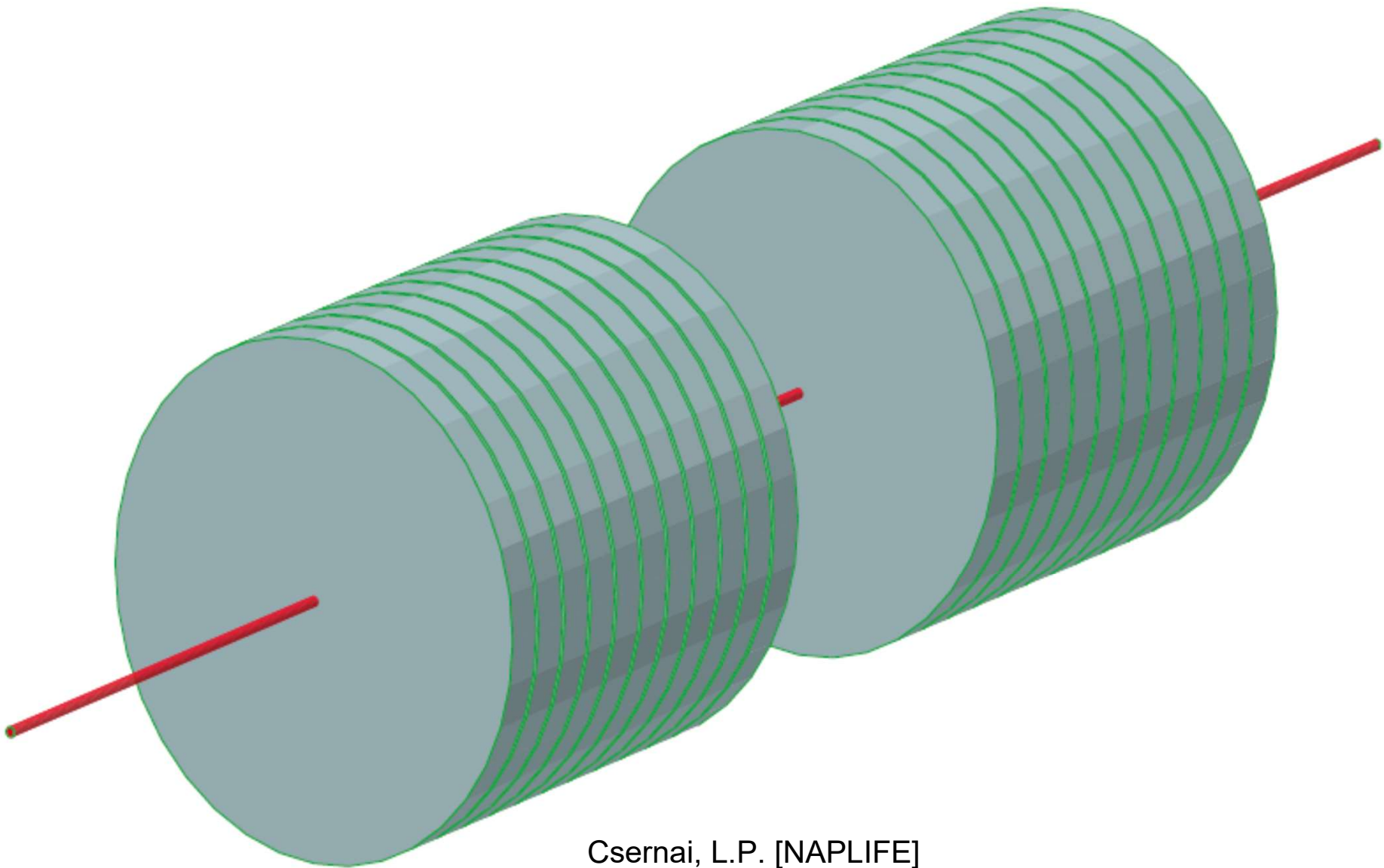

Laser Wake Field Collider

∃ Pre-compression/acceleration, before ignition

Ion (e.g. p) Energy $E_p \approx 50$ MeV (or more)

Initial beam densities assumed: $n_H \approx \gamma n_0 = 2 \cdot 10^{-19}/\text{cm}^3$ and $2 \cdot 10^{-21}/\text{cm}^3$

$\approx n_{\text{liquid-H}}$, $\approx n_{\text{NIF}} / 1000$ (/wo precompression!)

Target density after interpenetration: $n_t \geq 2 n_H$

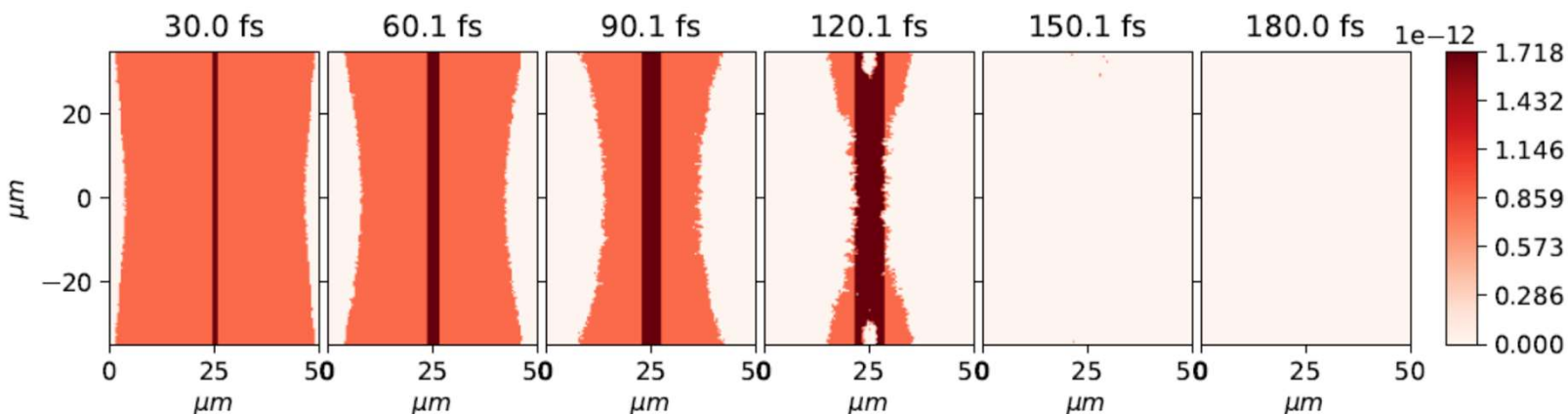

The ionization of the H atoms at ignition in a Laser Wake Field (LWF) wave due to the irradiation from both the +/- x directions

[Papp, I., et al., NAPLIFE, Phys. Lett. A 396, 12724 (2021).]

Csernai, L.P. [NAPLIFE]

Laser Wake Field Collider

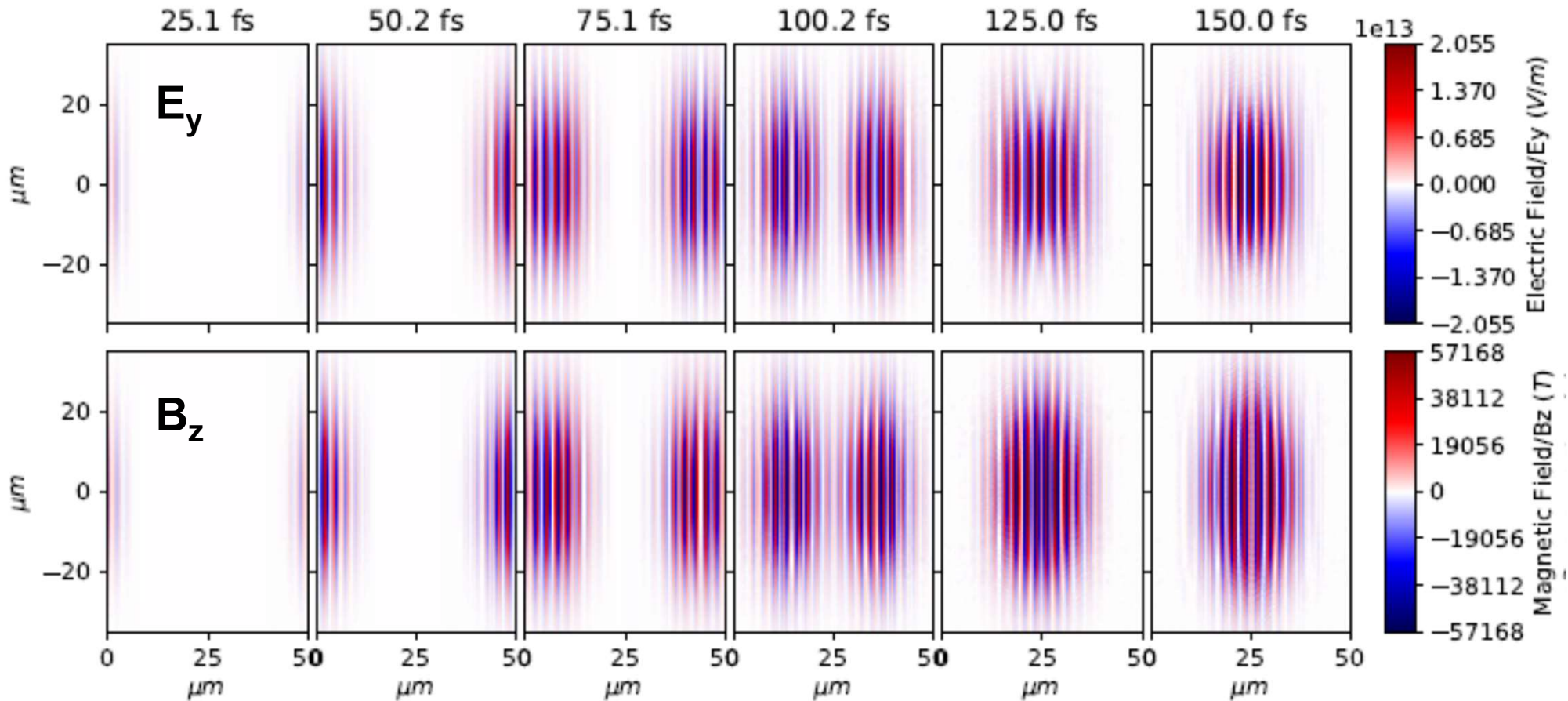

The electric field, E_y (top) and magnetic field, B_z (bottom) in a Laser Wake Field (LWF) wave formed by irradiation from the $\pm x$ - direction. The rest number density of the H target is $n_H = 2.13 \cdot 10^{25}/\text{m}^3 = 2.13 \cdot 10^{19}/\text{cm}^3$. The laser beam wavelength is $\lambda = 1\mu\text{m}$. The LWF wavelength is about 20λ . **Pulse energy is 19.6 J.**

Validation tests →

**Laser Induced Fusion
with Nanoantennas**

Deuterium production w

ith 795nm 40fs Ti:Sa laser 10^{16} - 10^{17} W/cm² intensity

UDMA-TEGDMA target 20-100 μ m thick, \w & \wo Au nanorods 25x85nm.

→ 5 mJ pulse -> crater of 4.55 - $1.07 \cdot 10^{14}$ μ m³ \w & \wo Au $\sim 15/ \mu$ m³

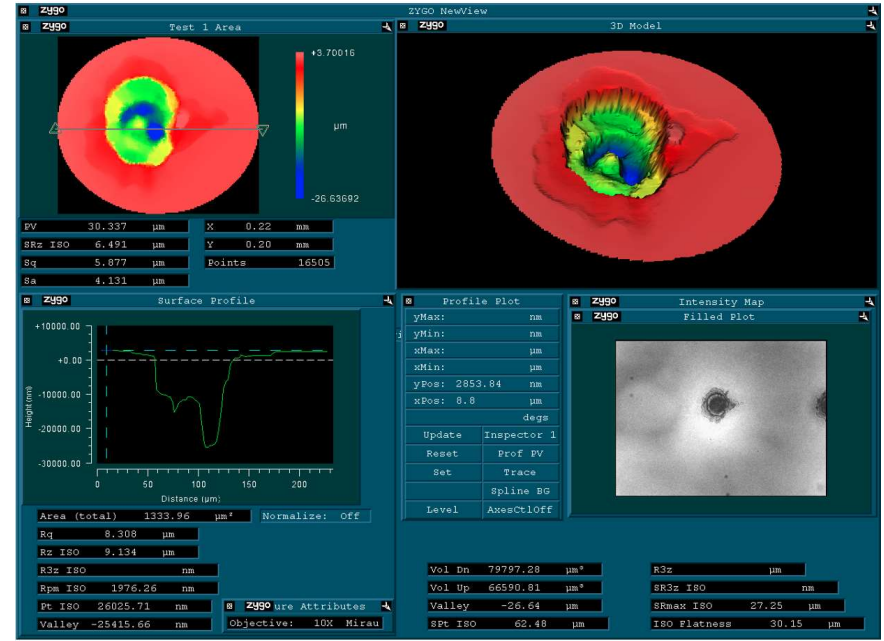
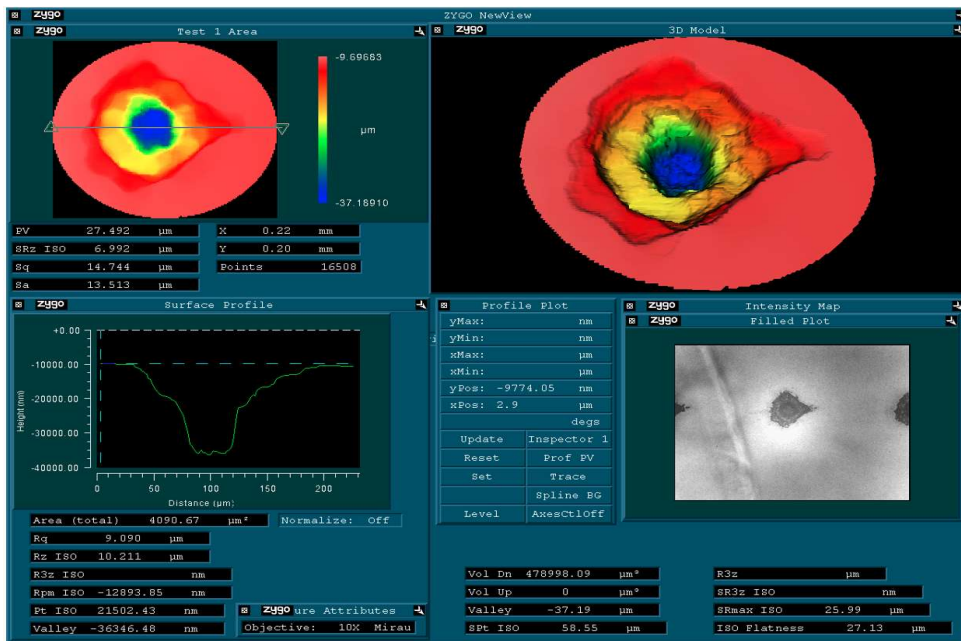

→ From the crater the emitted matter was analysed by Raman spectroscopy & Laser Induced Breakdown Spectroscopy (LIBS).

Deuterium production

(PRELIMINARY !)

(N.K.*)

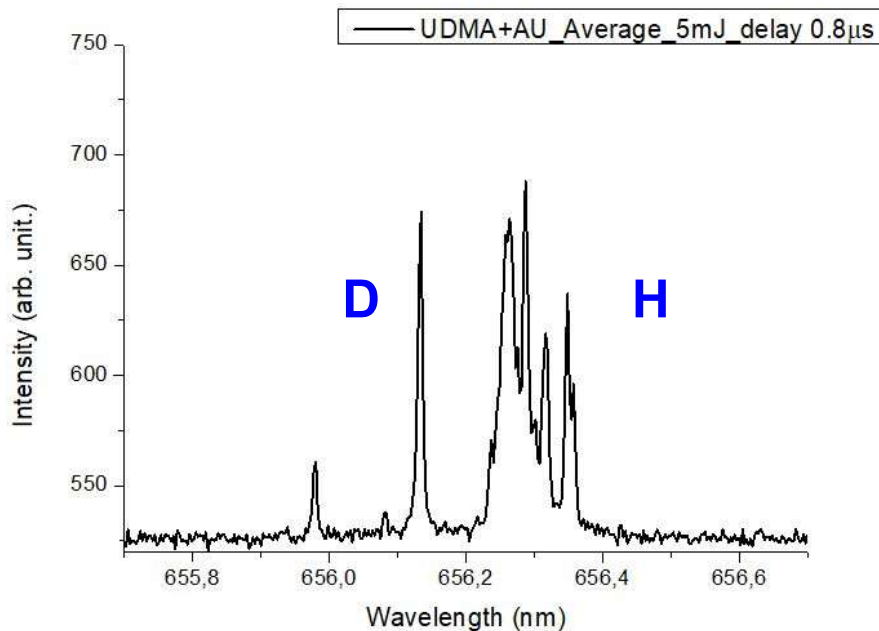

5-12% D + 88-95% H

~ 10^{17} D / pulse (10Hz)

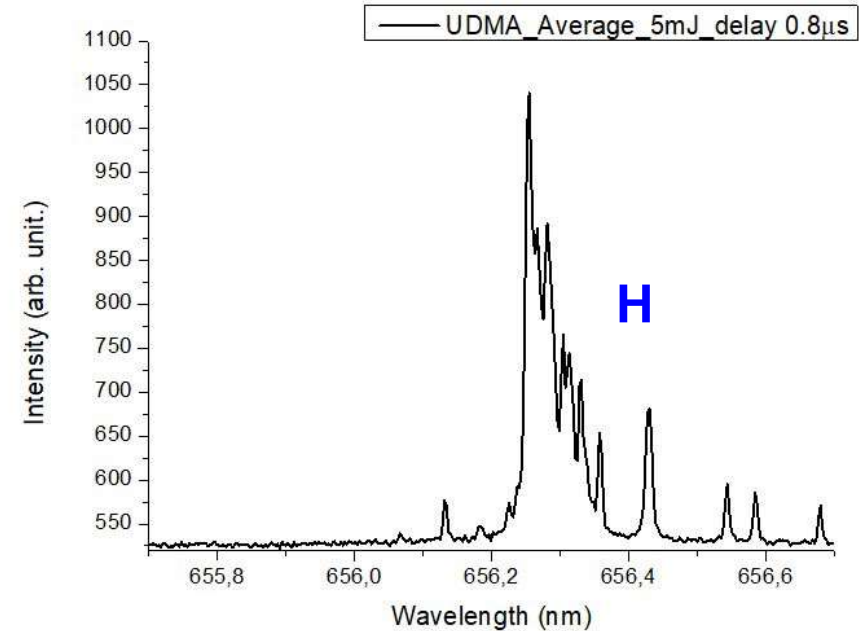

100% H

Balmer- α line

Two step process (average of 20 shots):



Electron capture may happen spontaneously in heavy nuclei,

here laser light and resonant nanorods act similarly, high e^- density

UDMA (470: H38, C23, O8, N2)

**High Energy, Short Pulse Laser,
unique
at
ELI – ALPS
Szeged**

A man in a dark suit and white shirt stands on a paved walkway in front of a large, modern building with a distinctive, angular, metallic facade. The building's facade is composed of dark, perforated panels that create a grid-like pattern. The sky is clear and blue. The man is holding a black bag and is looking towards the camera. The overall scene is brightly lit, suggesting a sunny day.

**European Laser
Infrastructure
ELI-ALPS
Szeged, HU**

Csernai, L.P. [NAPLIFE]

European Laser Infrastructure – Szeged, HU



ELI-ALPS Szeged:
EU Extr. Light Infrastructure
Attosec. Light Pulse Source

2PW High Field laser
10 Hz, <10fs, **20 J**

Csernai, L.P. [NAPLIFE]

Thanks for your attention

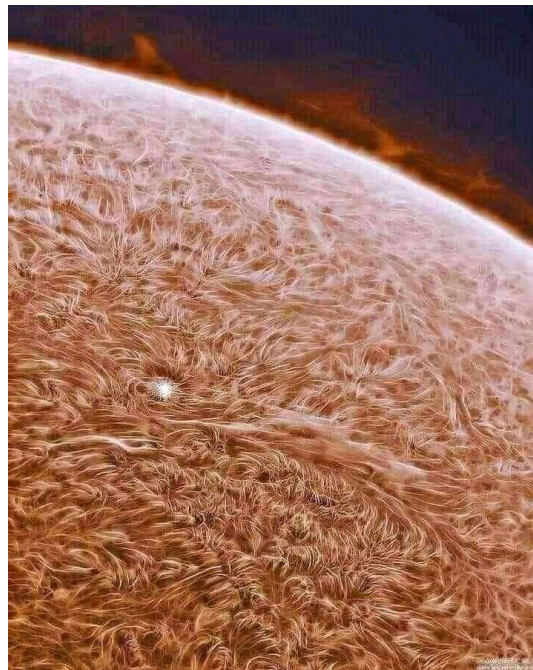

Csernai, L.P. [NAPLIFE]